

975

Instructional Audio System



Installation Guide





Important Safety Instructions

1. Do not use the apparatus near water.
2. Clean only with dry cloth.
3. Do not block any ventilation openings.
4. Do not install near any heat sources such as radiators, heat registers, stoves, or other apparatus (including amplifiers) that produce heat.
5. Do not defeat the safety purpose of the polarized or grounding-type plug.
A polarized plug has two blades with one wider than the other. A grounding-type plug has two blades and a third grounding prong. The wide blade or the third prong is provided for your safety. If the provided plug does not fit into your outlet, consult an electrician for replacement of the outlet.
6. Protect the power cord from being walked on or pinched particularly at plugs, convenience receptacles, and the point where they exit from the apparatus.
7. Unplug this apparatus during lightning storms or when unused for long periods of time.
8. Refer all servicing to qualified service personnel. Servicing is required when the apparatus has been damaged in any way, such as power-supply cord or plug is damaged, liquid has been spilled or objects have fallen into the apparatus, the apparatus has been exposed to rain or moisture, does not operate normally, or has been dropped.
9. When the mains plug or appliance coupler is used as the disconnect device, it shall remain readily operable.
10. Please keep the unit in a good ventilation environment.
11. WARNING: To reduce the risk of fire or electric shock, do not expose this apparatus to rain or moisture.
12. Apparatus shall not be exposed to dripping or splashing and no objects filled with liquids, such as vases, shall be placed on the apparatus.
13. WARNING: Battery pack shall not be exposed to excessive heat such as sunshine, fire or the like.

Table of Contents

OVERVIEW

- 2 Important Safety Instructions
- 4 Optional Speakers

INSTALLATION PLANNING

- 5 Location in the Classroom
- 5 Connecting the Power Supply

SPEAKER LOCATION & INSTALLATION

- 6 TCQ Speaker Installation
- 12 DRQ Ceiling Speaker Installation
- 15 WMQ Wall Speaker Installation
- 17 4JCS Ceiling Speaker Installation
- 20 Connecting Speaker Wires

SET UP & INTEGRATION

- 21 Charging the Microphones
- 22 Operating the Microphone
- 23 Audio Integration

INSTALLING OPTIONAL EQUIPMENT

- 24 Life Safety Solutions
- 27 Optional Activate Charging Station Set-Up
- 31 Media Connector Set-Up

TROUBLESHOOTING

- 34 Common Problems and Solutions
- 34 Tips to Obtain Optimum Audio Performance



Optional Speakers

Systems can be configured with a variety of different speaker types, including the following:

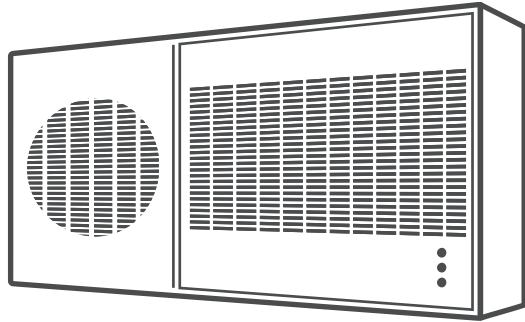

TCQ (x 1)
Ceiling-mounted speaker

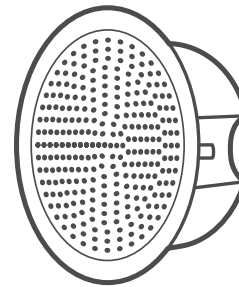

DRQ (x 4)
Ceiling-mounted speakers

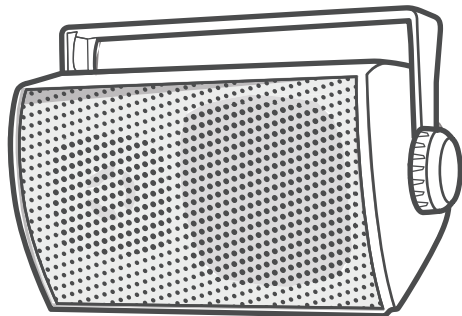

WMQ (x 4)
Available in U.S. and Canada only

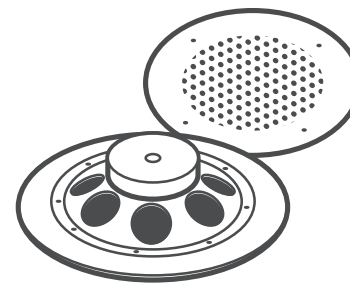

4JCS (x 4)
Plenum rated. Available in U.S. only



INSTALLATION PLANNING

Location in the Classroom

First, find a suitable location to set-up the 975. It is best to put the amplifier in a stable location near other equipment to be used.

It can be set in a cabinet, on a tabletop, or mounted on the wall. The 975 may be wall-mounted using the molded screw flanges. Appropriate mounting hardware should be purchased locally.

Avoid separated set-ups: Components should be housed together. Wires should be routed back directly to the 975.

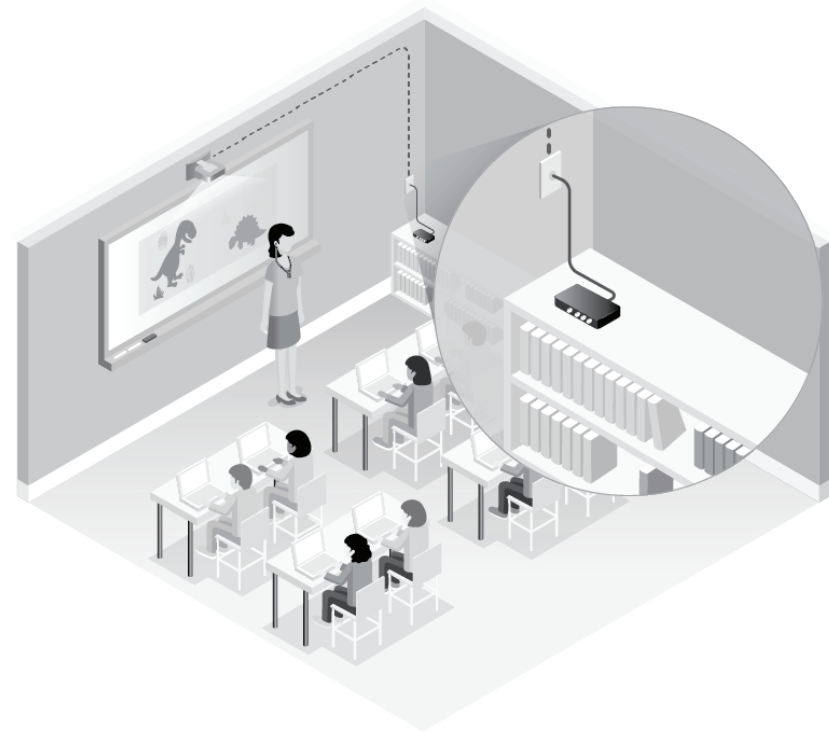

Connecting the Power Supply

- Connect the DC end of the power supply to the jack labeled POWER.
- Connect the AC power cable from the power supply to a wall outlet.

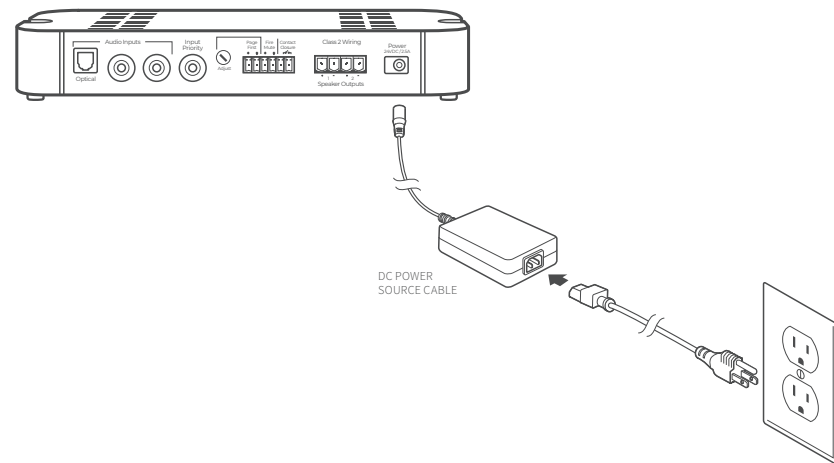

SPEAKER LOCATION & INSTALLATION

TOOLS AND EQUIPMENT TO INSTALL THE SPEAKERS OUTLINED IN THIS MANUAL

Locate the specific speaker(s) that were ordered with the system and then follow the installation instructions for the model of speaker outlined in this section of the manual.

- Straight edge
 - Utility knife or drywall saw
 - Screwdriver, standard and phillips
 - Screwdriver, small jewelers type, 1/8" wide tip
 - Drill driver and bits/drills
 - Drill driver and bits/drills
- Drill driver and bits/drills
 - Marker or pencil
 - Wire cutters
 - Wire strippers
 - Wire ties

TCQ Speaker Installation

SYSTEM COMPONENTS AND UNPACKING

- (1) Ceiling grid T-bar (US & Canada use)
- (1) 50 ft (15m) plenum rated speaker wire (if ordered)
- (1) 19 ft (6m) coil safety wire
- (4) Self drilling screws (outside U.S. and Canada)

NOTE: Wiring should follow the class 2 wiring methods as outlined in the National Electric Code.

SELECTING SPEAKER MOUNTING LOCATIONS

One TCQ speaker will distribute sound throughout a classroom of up to 1,200 sq ft (112 sq m). The location of the speaker is important to ensure even sound distribution. Ceiling height should be 9 - 12 ft (2.75m - 3.75m).

1. Identify the center of the of the classroom for optimum location.
2. Select a ceiling tile that is free from fixtures (lighting, HVAC, etc.) within a 6 ft (1.8m) radius nearest to the center point.
3. Remove the selected ceiling tile for speaker installation.

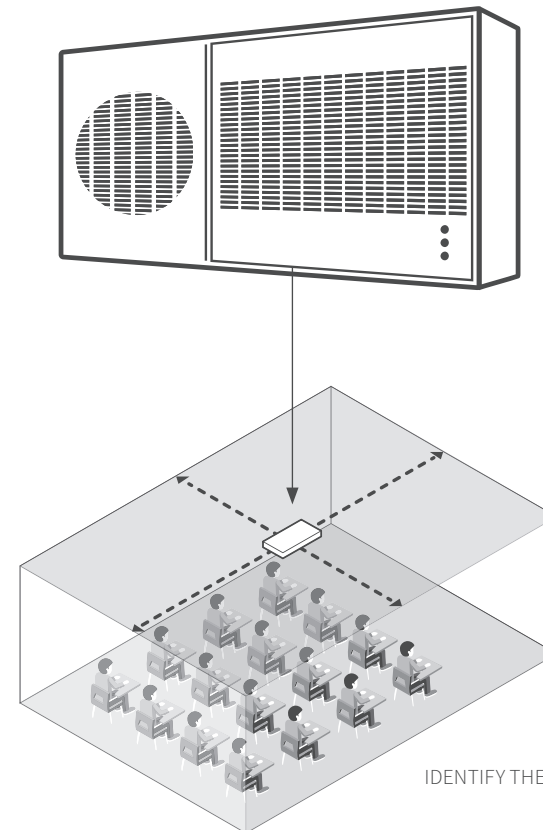

IDENTIFY THE CENTER OF THE ROOM

GRID CEILING INSTALLATION (U.S. & CANADA ONLY)

The dimensions of the TCQ are 1' x 2'. It is designed to fit into any standard 2' X 4', or 2' X 2" suspended ceiling tile grid.

1. The ceiling tile will need to be cut to accommodate the TCQ
2. Set the ceiling tile on a flat work surface with the patterned side facing down.
3. Using a straight edge, cut a 1' x 2' section from the ceiling tile, creating a 1' x 2' section and a 3' x 2' section, or two 1' x 2' sections depending on the size of your tiles.

2' X 4' CEILING TILE

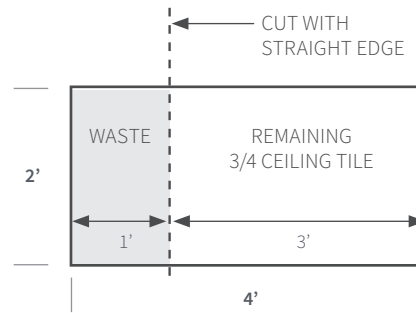

CUT THE 2' X 4' TILE TO CREATE A 1' X 2' SECTION AND A 3' X 2' SECTION.

2' X 2' CEILING TILE

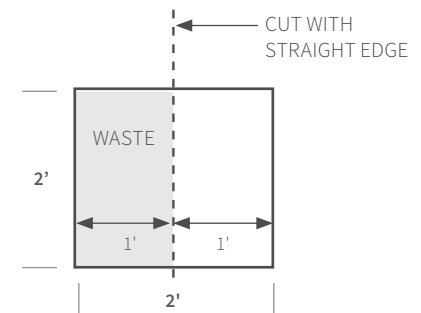

CUT THE 2' X 2' TILE TO CREATE TWO 1' X 2' SECTIONS

4. Locate the 2' ceiling grid t-bar attachment. Locate the attachment slots in the existing ceiling grid and snap the new T-bar into place to create a 1' x 2' and 2' x 3' sections, or two 1' x 2' sections.

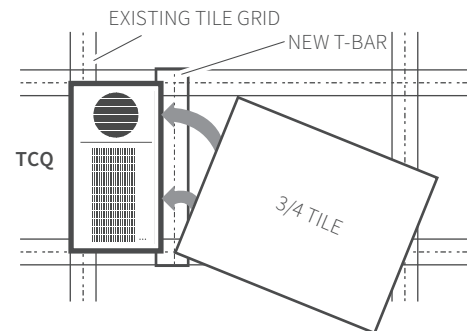

SNAP THE T-BAR INTO PLACE TO CREATE A 1' X 2' OPENING AND A 3' X 2' OPENING

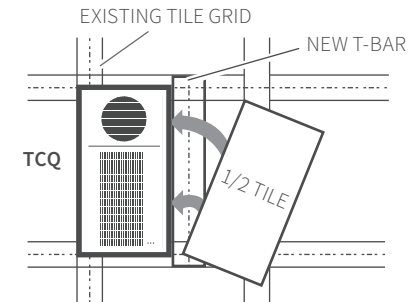

SNAP THE T-BAR INTO PLACE TO CREATE TWO 1' X 2' OPENINGS

SECURING THE TCQ SPEAKER (U.S. & CANADA ONLY)

To comply with Building Codes, the TCQ *MUST* be secured to the building structure with two safety wires.

1. Locate the safety wire. The safety wire needs to be permanently attached to the solid building structure with metal clips, tie point studs, concrete anchors or eye screws designed for the specific structure material. The specific anchors will need to be provided by the installer.
2. Cut the safety wire in half.
3. Install the appropriate anchor into the building structure (see figure 6).
4. Loop one end of the safety wire through the anchor (or eye screw), then twist it around itself at least five times. Repeat for the second anchor tie point.
5. Place the TCQ into the desired grid location.



Caution: Make sure the TCQ is stable on the grid rails with side brackets capturing the T-bar grid. If not stable, there could be a danger of it falling until safety wires are attached.

6. Loop the other end of the safety wire through one of the tabs on the TCQ (located in opposite corners). Pull the wire through until it is taut and twist it around itself at least five times to secure the TCQ and cut off any excess wire if needed (see figure 7).
7. Repeat with securing the second safety wire to the other tab.

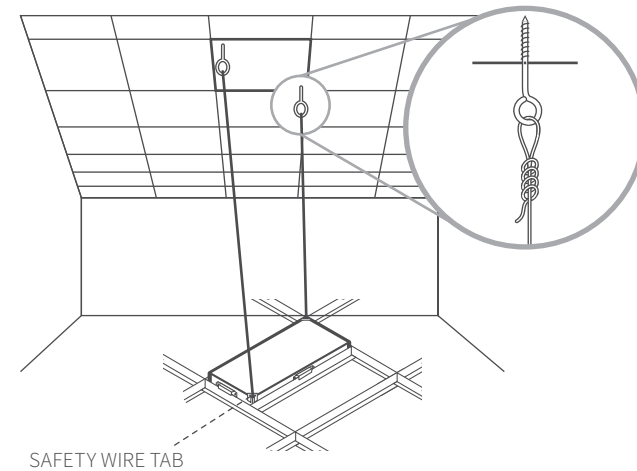

FIGURE 6:
ATTACHING THE SAFETY WIRE TO THE BUILDING STRUCTURE

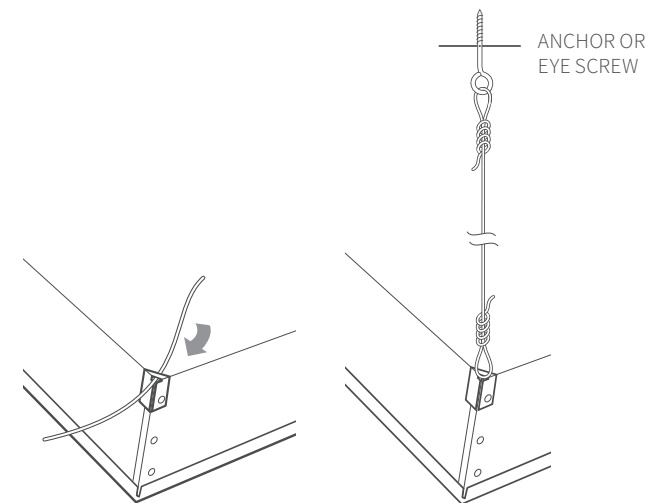

FIGURE 7:
SECURE THE WIRE IN THE TWO SAFETY WIRE TABS

SECURE TO CEILING GRID (U.S. & CANADA ONLY)

1. Locate the four (4) self-drilling sheet metal screws.
2. Utilizing existing holes on the vertical section of the ceiling rail (center of the hole to the base of the rail must be a minimum of 0.6", drill two screws on each 2' side of the TCQ (see figure 8). Drilling these screws into the designated areas of the TCQ chassis will not cause harm to the product.

NOTE: Do not drill in the area designated with yellow tape as this could affect audio quality and void the warranty.

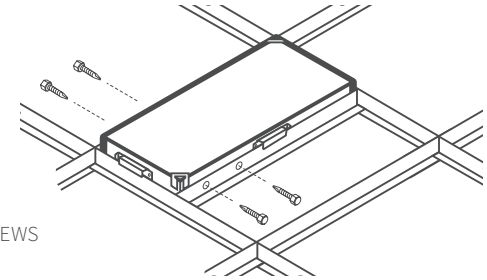

FIGURE 8:
SECURE TCQ TO CEILING RAIL WITH SELF-DRILLING SCREWS

CONNECT SPEAKER WIRES

1. Find and open the front panel door on the TCQ by sliding the door toward the end of the TCQ to disengage the lock (see figure 9A).
2. Run speaker wire through back of speaker and into the terminal block area. Use appropriate conduit connector or cable bushing/grommet (not supplied) as needed for the 1/2" opening (see figure 10).
3. Attach the two wires to the terminal block screws as indicated (see figure 11). Spade lugs are provided that can be attached to the speaker wire, if desired.
4. Close speaker door securely by applying pressure outward on the main body of the TCQ. Then slide the door toward the middle of the unit and lock into place (see figure 9B).
5. To continue with installation, go to Page22: *Connecting Wire to Amplifier*.

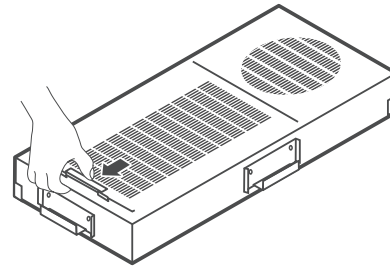

FIGURE 9A:
OPEN FRONT PANEL

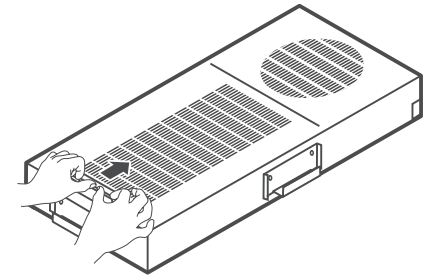

FIGURE 9B:
CLOSE FRONT PANEL

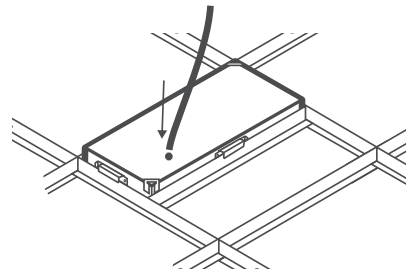

FIGURE 10:
OPENING FOR SPEAKER WIRES

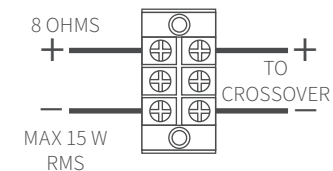

FIGURE 11:
TERMINAL BLOCK

SECURING THE TCQ SPEAKER (U.S. & CANADA ONLY)

FOR 600MM X 600MM CEILING GRID

To comply with Building Codes, the TCQ *MUST* be secured to the building structure with two safety wires.

The TCQ has spacer brackets mounted on each of the four sides. With these brackets installed, the TCQ will fit a standard 2' x 2' suspended ceiling grid. With the brackets removed, it will fit a 600mm x 600mm ceiling grid.

Remove the spacer brackets from each of the four sides of the TCQ. Replace the two screws into the woofer end of the speaker cabinet to ensure proper audio quality

Note: If your ceiling grid is any other dimension than mentioned above, contact your local Lightspeed representative.

1. Locate the 6m length of safety wire. The safety wire needs to be permanently attached to the solid building structure with metal clips, tie point studs, concrete anchors or eye screws designed for the specific structure material. The specific anchors will need to be provided by the installer.
2. Cut the safety wire in half.
3. Install the appropriate anchor into the building structure (see figure 1).
4. Loop one end of the safety wire through the anchor (or eye screw), then twist it around itself at least five times. Repeat for the second anchor tie point.
5. Place the TCQ into the desired grid location.



Caution: Make sure the TCQ is stable on the grid rails with side brackets capturing the T-bar grid. If not stable, there could be a danger of it falling until safety wires are attached.

6. Loop the other end of the safety wire through one of the tabs on the TCQ (located in opposite corners). Pull the wire through until it is taut and twist it around itself at least five times to secure the TCQ and cut off any excess wire if needed (see figure 2).
7. Repeat with securing the second safety wire to the other tab.

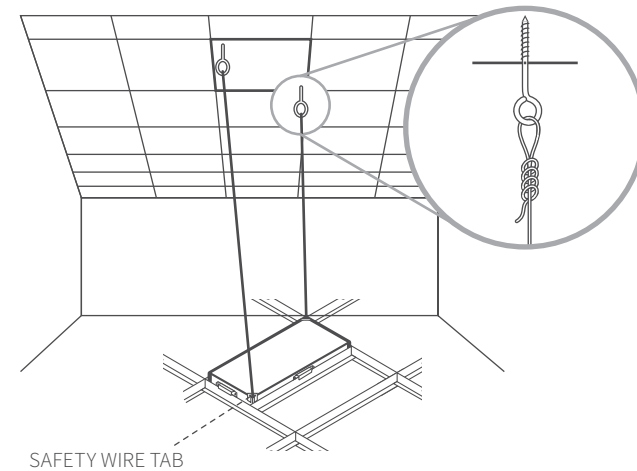

FIGURE 1:
ATTACHING THE SAFETY WIRE TO THE BUILDING STRUCTURE

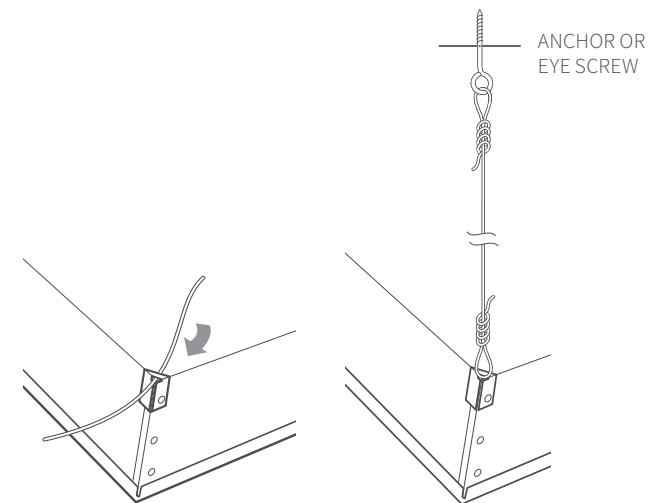

FIGURE 2:
SECURE THE WIRE IN THE TWO SAFETY WIRE TABS

SECURE TO CEILING GRID (OUTSIDE U.S. & CANADA ONLY)

1. Locate the four (4) self-tapping sheet metal screws.
2. Utilizing existing holes on the vertical section of the ceiling rail (center of the hole to the base of the rail must be a minimum of 15mm - see figure 8), drill two screws on each 600mm side of the TCQ (see figure 15). Drilling these screws into the designated areas of the TCQ chassis will not cause harm to the product (see figure 15).
NOTE: Do not drill in the area designated with yellow tape as this could affect audio quality and void the warranty.

3. To continue with installation, go to Page 22: *Connecting Wire to Amplifier*.

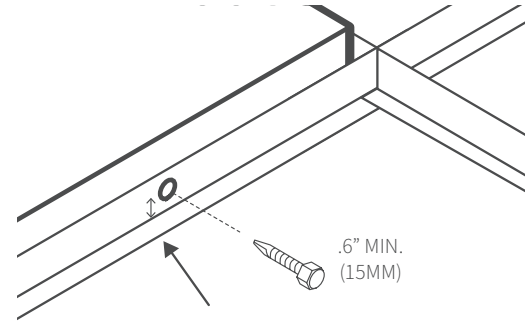

FIGURE 1:
SECURE WITH SELF-TAPPING SCREWS INTO THE TCQ

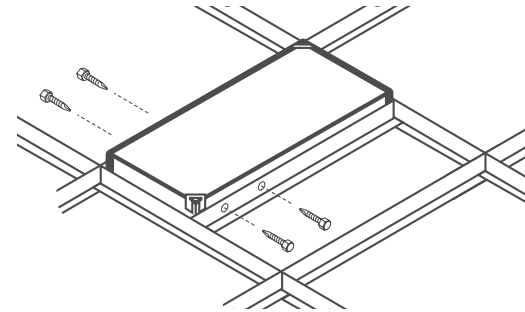

FIGURE 2:
SECURE WITH SELF-TAPPING SCREWS INTO THE TCQ

DRQ Ceiling Speaker Installation

Tools and Equipment

- Small flathead screwdriver
- Philips screwdriver
- Marker or pencil
- Drywall saw

Speaker Components

- (4) DRQ speakers
- (4) Tile bridges
- (2) 30 ft bundles of plenum-rated speaker wire (if ordered) marked with a white band
- (2) 50 ft bundles of plenum-rated speaker wire (if ordered) marked with a blue band

NOTE: Wiring should follow the class 2 wiring methods as outlined in the National Electric Code.

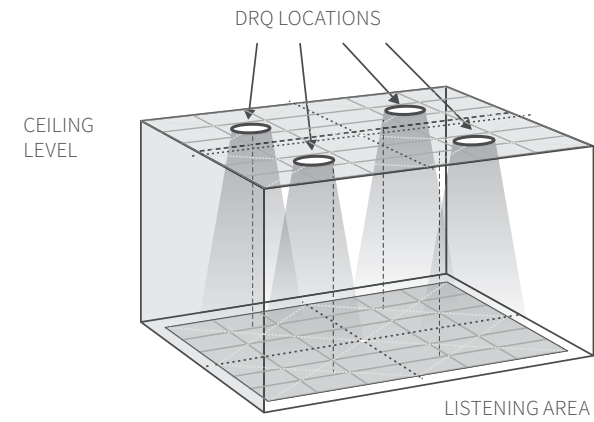

FIGURE 1:
SPEAKER PLACEMENT

SELECTING SPEAKER MOUNTING LOCATIONS

A standard system includes four ceiling speakers for rooms up to 1600 sq ft (148sqm) with a ceiling height of 9-12 feet (2.75m - 3.75m). The location of the speakers is critical for even sound distribution.

1. Quarter the classroom into four equal quadrants (see figure 1).
2. Select a ceiling tile that is centered in each quadrant.
3. Remove the selected ceiling tiles for speaker installation.

DIVIDE THE LISTENING
AREA INTO QUARTERS
AND CENTER SPEAKERS
IN EACH SECTION

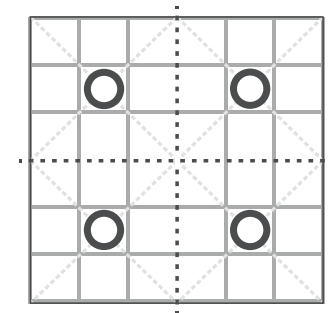

INSTALLING THE SPEAKERS INTO THE CEILING TILE

Before beginning the speaker tile work, choose a flat work surface

1. Lay the tile bridge across the backside of the ceiling tile as shown in figure 2. Using a marker or pencil, trace out the cutout circle as a template.
2. Using a drywall saw or jigsaw, cut out a circular hole as neatly as possible.
NOTE: to ensure the hole is large enough, cut slightly outside the mark.

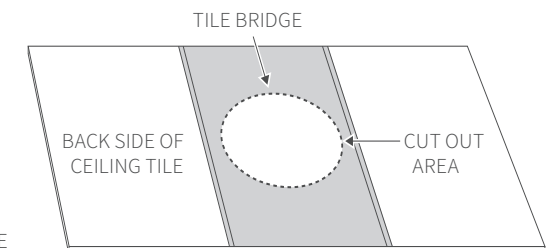

FIGURE 2:
CUTTING THE TILE

3. Remove the speaker grille by turning and pushing one of the arms upward (see figure 3). Or use the grille removal tool, insert one end into one of the holes near the edge and pull the grille off.
4. Turn the tile on its side and insert the speaker into the front side of the tile. Place the tile bridge around the backside of the speaker, oriented horizontally across the tile (as shown in figure 2).
5. Use a screwdriver (or screwgun) to tighten the four mounting screws (see figure 4). NOTE: the first quarter turn pulls the mounting tabs away from the speaker enclosure, then it begins tightening.
6. Repeat steps 1-5 for each speaker and tile.

FIGURE 3:
REMOVE THE GRILLE

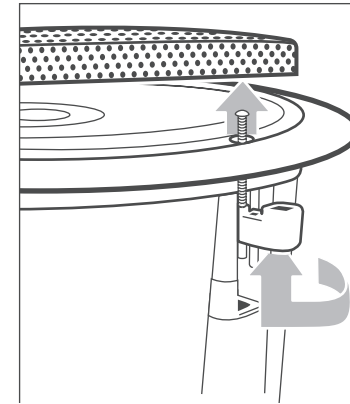
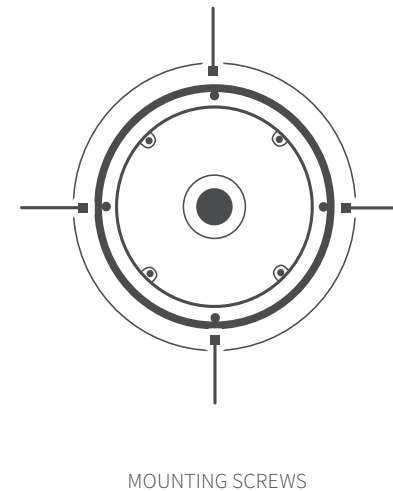

FIGURE 4:
MOUNT SPEAKER



MOUNTING SCREWS



NOTE: Building codes vary from state to state and county to county. It may be required that the speaker itself be secured to a support wire.

CONNECTING AND ROUTING SPEAKER WIRE

Prep two conductor 18 awg plenum rated speaker wire ends for insertion into the speaker connectors.

NOTE: it is advised to prep and connect each speaker at ground level.

1. Distribute the appropriate lengths of wire to each speaker (see figure 5). There should be (2) 30 ft lengths of wire between two pairs of speakers. There should be (2) 50 ft lengths of wire for home runs back to the amplifier.
2. At Speaker #1, remove the euro-block connector on the back of the speaker.
3. Connect one length of speaker wire to the -+ terminals marked as INPUT on the speaker, paying attention to polarity (BLACK is “-”, RED is “+”). Tighten the screw on bottom of the connector with small screwdriver to secure. This length of wire will be routed back to the amplifier.
4. Connect a second length of speaker wire to the second set of -+ terminals marked as OUTPUT on the speaker, paying attention to polarity. Tighten the screws to secure. This wire will be routed to Speaker #2.
5. Route the wire to Speaker #2. Secure and conceal wire as needed.
6. At Speaker #2, remove the euro-block connector.
7. Connect the wire to the input set of -+ connectors, paying attention to polarity and tighten the screws on top to secure.
8. Repeat 2 through 7 to connect Speakers #3 and #4. Note that only two speakers can be wired together per amplifier output (minimum 4 ohm load).
9. Route the wires from Speaker #1 and #3 back to the amplifier as indicated in figure 5. Note that there must be a service loop of 8 to 10 ft at the speakers and the speaker wire cut to length at the amplifier.
10. Secure all speaker wire above the ceiling tiles with wire ties or wiring clips and use surface mounted raceway for any exposed wiring coming down the wall to the amplifier. This is required by code in most, if not all jurisdictions.
11. To continue with installation, go to Page 22: *Connecting Wire to Amplifier*.

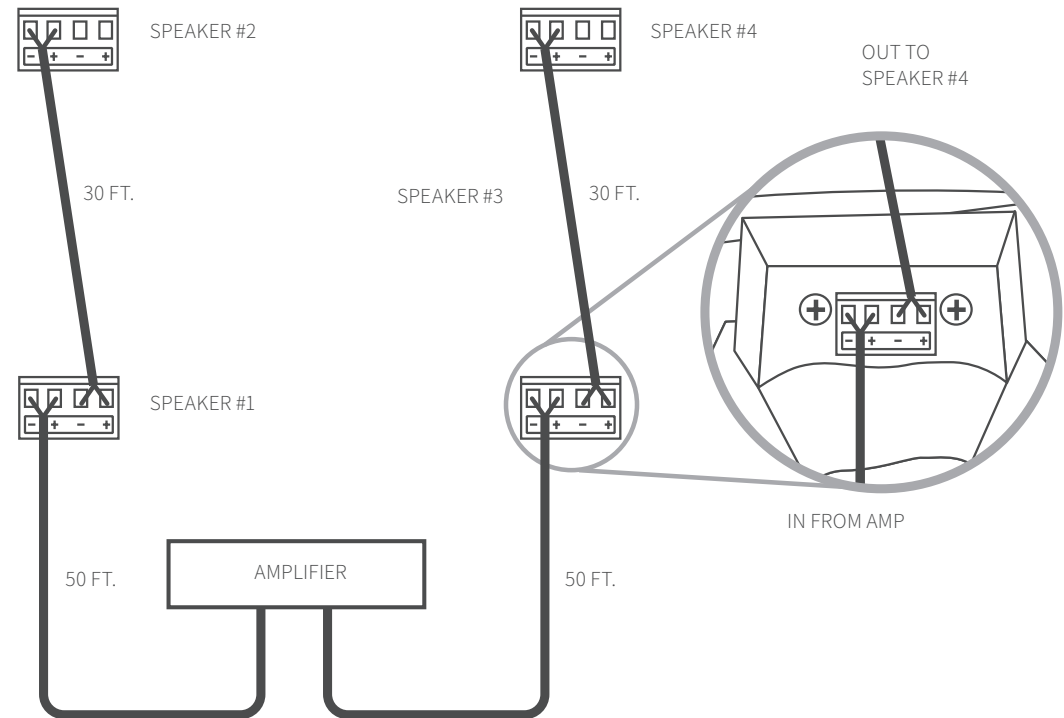



WMQ Wall Speaker Installation

Tools and Equipment

- Small flathead screwdriver
- Drill with 3/16" (.1875mm) drill bit
- Phillips head screwdriver
- Marker or pencil

NOTE: Wiring should follow the class 2 wiring methods as outlined in the National Electric Code.

Speaker Components

- (4) WMQ speakers
- (4) Wall mount brackets
- (4) Sets of mounting hardware (screws and drywall anchors)
- (2) 50 ft bundles of plenum-rated speaker wire (if ordered) marked with a blue band
- (2) 75 ft bundles of plenum-rated speaker wire (if ordered) marked with a red band

SELECTING SPEAKER MOUNTING LOCATIONS

A standard system includes 4 wall speakers for rooms up to 1600 sq ft (148 sq m) with a ceiling height of 8-12 feet (2.4 - 3.75m). The location of the speakers is critical for even sound distribution.

1. Refer to figure 1 for speaker positioning recommendations.
2. Ideally speakers should be staggered on all four walls (Optimum).
3. When all four walls are not available, refer to the other diagrams for alternative positioning.
4. Speakers should not be positioned directly opposite of one another.
5. When speakers are mounted, they should be tilted down toward the specific listening area indicated on the diagrams.
6. Depending on ceiling height, speakers should be placed 7.5 ft to 12 ft high (2.35 - 3.75m).
7. If the walls are drywall, drill pilot holes with a 3/16" (.1875mm) drill bit, then screw in the supplied drywall anchors.
8. While holding the bracket against the wall, drill the mounting screws into the drywall anchors (or directly into a stud).

OPTIMUM
SPEAKERS ON 4 WALLS

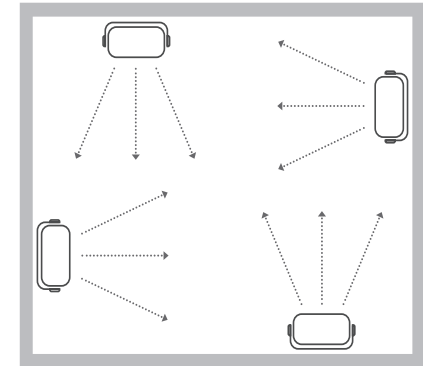

GOOD
SPEAKERS ON 3 WALLS

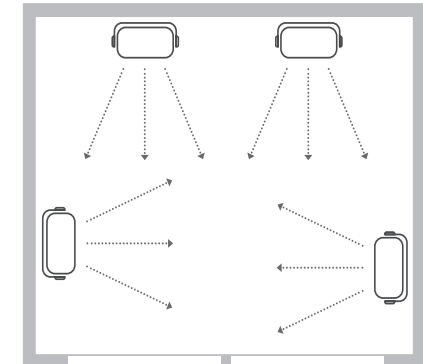

WINDOWS

OKAY
SPEAKERS ON 2 WALLS
(ONLY IF NECESSARY)

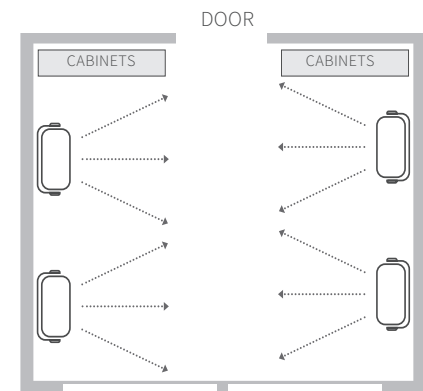

WINDOWS

9. Place the WMQ speaker between the two bracket arms, aligning the mounting holes.
10. Insert the large plastic mounting screws into the two sides of the speaker and tighten with your fingers.
11. Direct the speaker at the appropriate angle to cover the desired area of the classroom (see figure 1).

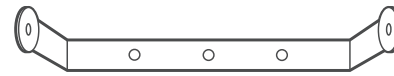

WALL BRACKET

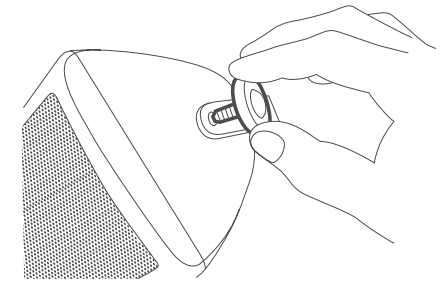

MOUNTING THE SPEAKER

CONNECTING AND ROUTING SPEAKER WIRE

Locate the plenum rated wire included with the speaker components (If ordered).

1. Distribute the appropriate lengths of wire to each speaker (see figure 3). There should be (2) 50 ft lengths of wire between two pairs of speakers. There should be (2) 75 ft lengths of wire for home runs back to the amplifier.
2. At Speaker #1, remove the euro-block connector on the back of the speaker.
3. Connect one 75 ft length of speaker wire to the +- connector, paying attention to polarity (BLACK is “-”, RED is “+”). Tighten the screw on top of the connector with small screwdriver to secure. This length of wire will be routed back to the amplifier. Note that there must be a service loop of 8 to 10 ft at the speaker and the speaker wire cut to length at the amplifier.
4. Connect a 50 ft length of speaker wire to the second set of +- jacks on the connector (see figure 3) paying attention to polarity. Tighten the screws to secure and plug the connector back into the speaker. This wire will be routed to Speaker #2.
5. Route the wire to Speaker #2. Secure and conceal wire as needed.
6. At Speaker #2, remove the euro-block connector.
7. Connect the wires to the +- connectors on the input, paying attention to polarity. Tighten the screws on top to secure and plug back into the speaker.
8. Repeat 2 through 7 to connect Speakers #3 and #4.
9. A 75 ft length of wire will be routed back to the amplifier. Note that there must be a service loop of 8 to 10 ft at the speaker and the speaker wire cut to length at the amplifier.
10. To continue with installation, go to Page 22: *Connecting Wire to Amplifier*.

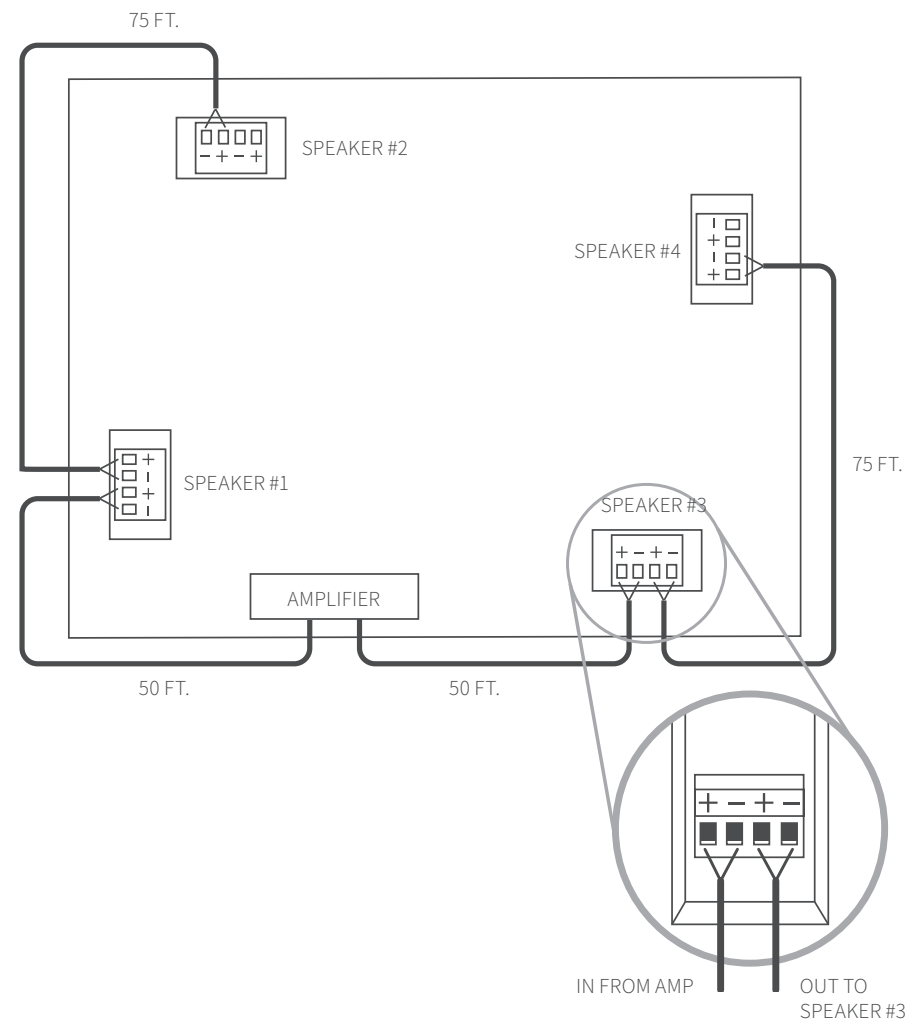

4JCS Ceiling Speaker Installation

Tools and Equipment

- Straight edge
- Marker
- Scissors (template)
- Utility knife
- Screwdriver
- Plenum rated pass-through or conduit hardware (not included)

Speaker Components

- (4) Speaker/baffle assembly
- (4) Tile bridge
- (4) Speaker enclosure
- (16) Mounting screws
- (8) Wire nuts
- (2) 30 ft bundles of plenum-rated speaker wire (if ordered) marked with a white band
- (2) 50 ft bundles of plenum-rated speaker wire (if ordered) marked with a blue band

NOTE: Wiring should follow the class 2 wiring methods as outlined in the National Electric Code.

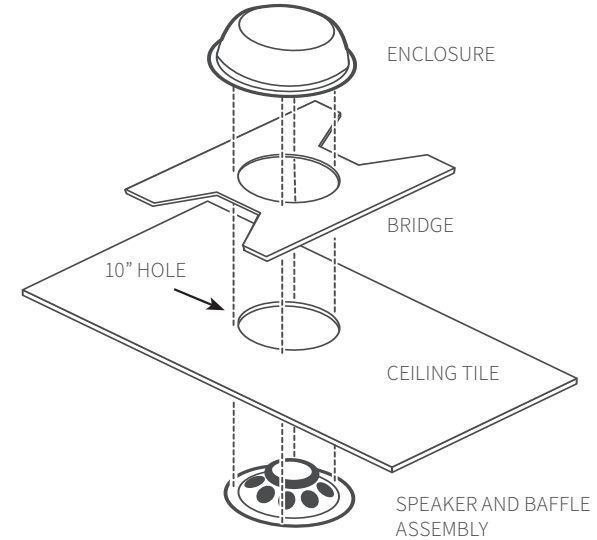

SELECTING SPEAKER MOUNTING LOCATIONS

A standard system includes four plenum-rated ceiling speakers for rooms up to 1,600 sq ft (148sqm) with a ceiling height of 9-12 feet (2.75m - 3.75m). The location of the speakers is critical for even sound distribution.

1. Quarter the classroom into four equal quadrants (see figure 1).
2. Select a ceiling tile that is centered in each quadrant.
3. Remove the selected ceiling tiles for speaker installation.

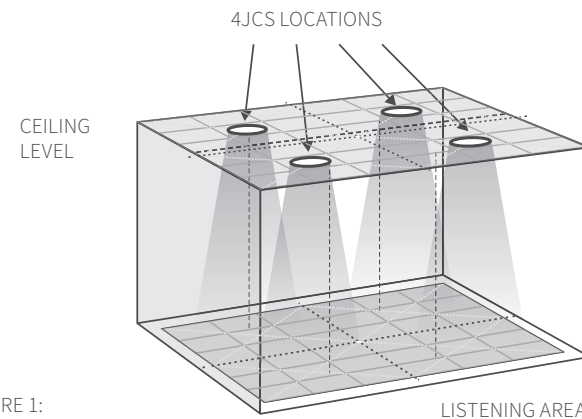
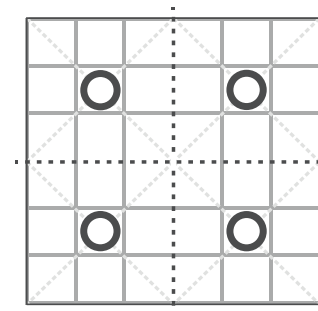

FIGURE 1:
SPEAKER PLACEMENT

DIVIDE THE LISTENING
AREA INTO QUARTERS
AND CENTER SPEAKERS
IN EACH SECTION



INSTALLING THE 4JCS SPEAKERS INTO THE CEILING TILE

Before beginning the speaker tile work, choose a flat work surface.

1. Using the straight edge, determine the center of each ceiling tile by drawing a straight line from corner to corner on the back of the tile.
2. Using the center point, mark a 10" circle on the back of the tile.
NOTE: A circular template is included (see figure 1A, 1B).
3. Using a utility knife or jigsaw, cut out the circular hole in the center of the tile as neatly as possible. The speaker baffle will cover up some minor rough edges.
NOTE: To ensure the hole is large enough, cut slightly outside template lines (see figure 1C).
4. Remove the speaker grille by turning and pushing one of the arms upward (see figure 2).
5. Turn the tile on its side and insert the speaker into the front side of the tile and place the tile bridge horizontally across the back of the tile. Holding the speaker and tile bridge in place, start all four of the mounting screws. Use a screwdriver to tighten the four mounting screws to secure the speaker, tile bridge and tile together.
6. Repeat steps 1 through 4 for each of the remaining speakers and tiles.

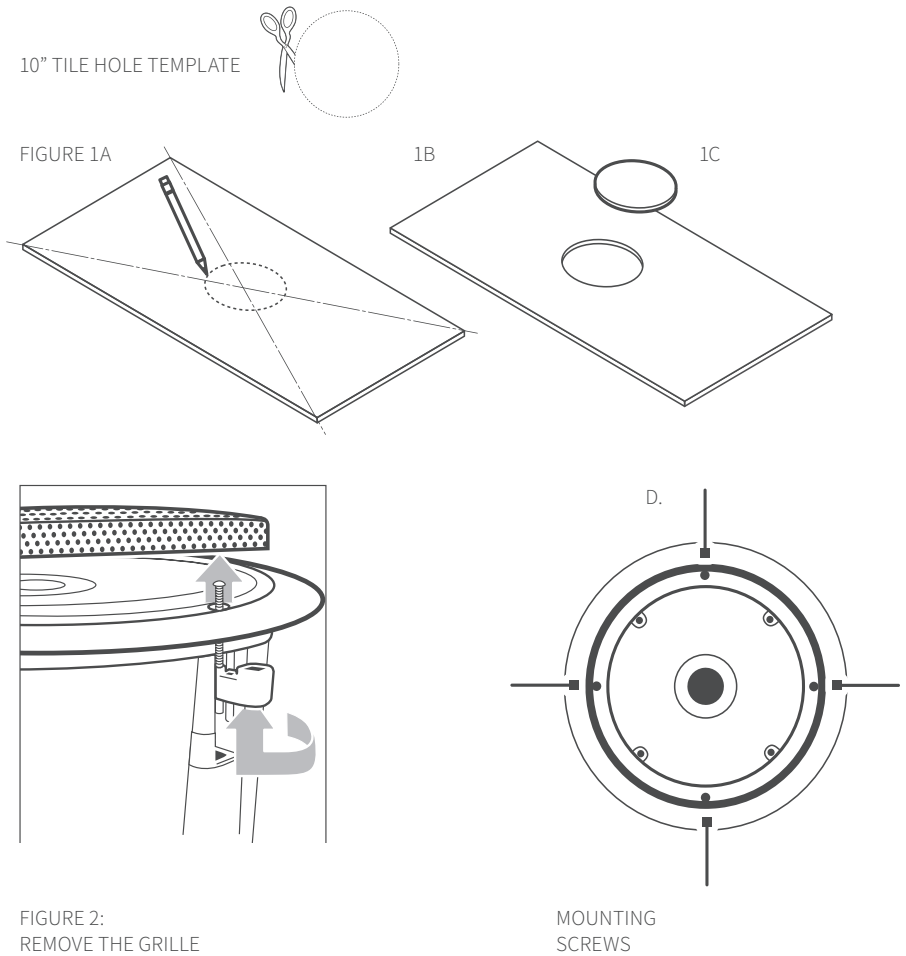

CONNECTING AND ROUTING SPEAKER WIRE

Prep two conductor 18 awg plenum rated speaker wire ends for insertion into the speaker connectors.

NOTE: it is advised to prep and connect each speaker at ground level.

1. Distribute the appropriate lengths of wire to each speaker (see figure 5). There should be (2) 30 ft lengths of wire between two pairs of speakers. There should be (2) 50 ft lengths of wire for home runs back to the amplifier.
2. Start with speaker #1 (see figure 4).
3. Remove a conduit knockout in the speaker enclosure and install a plenum-rated low voltage pass-through or conduit hardware in the enclosure (not included).
4. Route the speaker wire through the conduit hardware and attach to the speaker terminals by twisting the speaker wire and speaker pigtails together, securing with the included wire nuts. Be sure to maintain proper polarity (see figure 5).
5. Install the speaker enclosure on the tile bridge securing it in place by turning the enclosure clockwise (see figure 6).
6. Install speaker #1 with tile into the ceiling grid and route cabling (following local building codes) to speaker #2.

Note: Building codes vary from state to state and county to county. It may be required that the speaker itself be secured to a support wire.
7. Remove a conduit knockout in speaker #2's enclosure and install a plenum-rated low voltage pass-through or conduit hardware to the enclosure (not included).
8. Route speaker #1 wire and speaker #2 wire (50ft if ordered) through the conduit hardware and attach to the speaker terminals by twisting the speaker wire and speaker pigtails together, securing with the included wire nuts. Be sure to maintain proper polarity (see Figure 5).
9. Install the speaker enclosure on the tile bridge securing it in place by turning the enclosure clockwise (see Figure 6).
10. Install speaker #2 with tile into ceiling grid and route cabling (following local building codes) to the receiver/amplifier.
11. Repeat steps 3 through 10 for speakers #3 and #4.
12. To continue with installation, go to Page 31 - Connecting Wire to Amplifier.

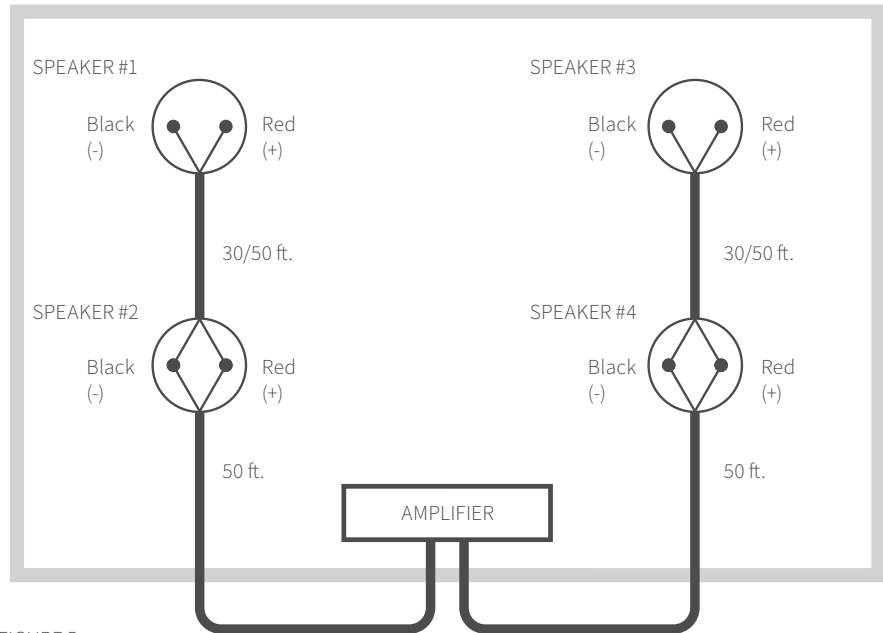

FIGURE 5:
WIRING DIAGRAM

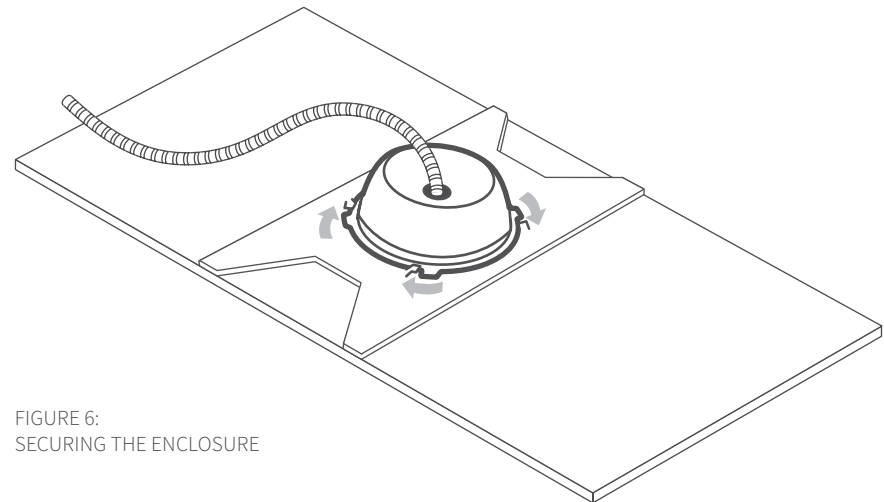
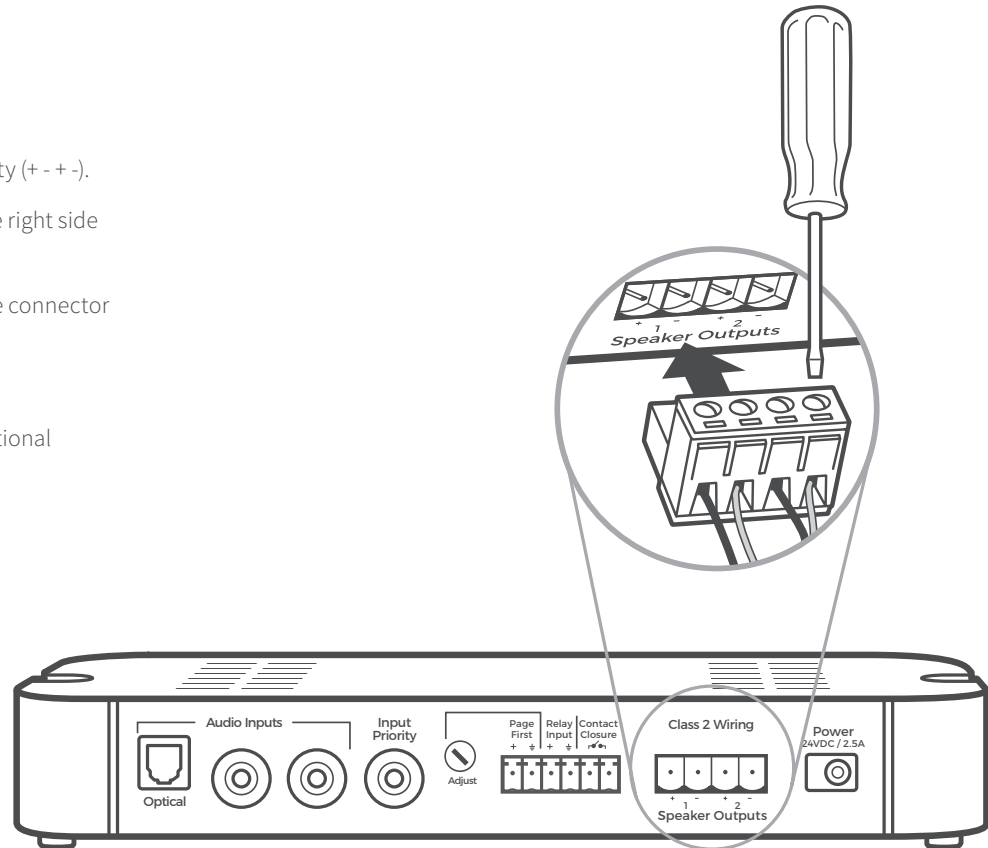

FIGURE 6:
SECURING THE ENCLOSURE

Connecting Speaker Wires

1. Unplug the euro-block SPEAKER OUTPUT connector from the amplifier.
2. Insert the two wires into the connector, paying close attention to polarity (+ - + -).
3. Insert the red (+) wire and black (-) wire from speakers #1 and #2 into the right side of the connector (SPEAKER OUTPUT 2).
4. Repeat with the 2nd wire from speakers #3 and #4 into the middle of the connector (SPEAKER OUTPUT 1), paying attention to polarity.
5. Plug the euro-block connector back into the amplifier.

NOTE: Wiring should follow the class 2 wiring methods as outlined in the National Electric Code.



CONNECTING SPEAKER WIRES TO BACK OF THE 975

SET UP & INTEGRATION

Charging the Microphones

BEFORE USE, THE MICROPHONES SHOULD BE CHARGED

Before use, the microphones should be charged. It will take 5-6 hours to obtain a full charge. A fully charged microphone will last for up to 8 hours of use. If microphones are used daily, they should be charged each night.

Replacement Lithium Ion battery pack may only be purchased through Lightspeed Technologies (part #L3.7V).

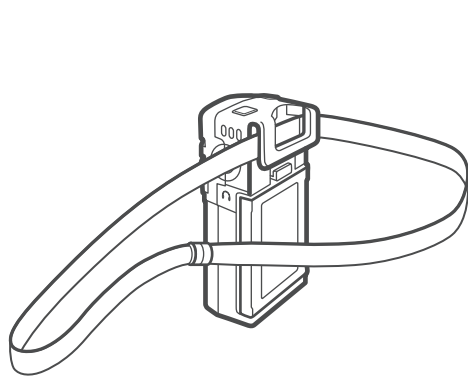

ATTACH LANYARD

Hang the Flexmike on the lanyard opposite the magnetic clasp.

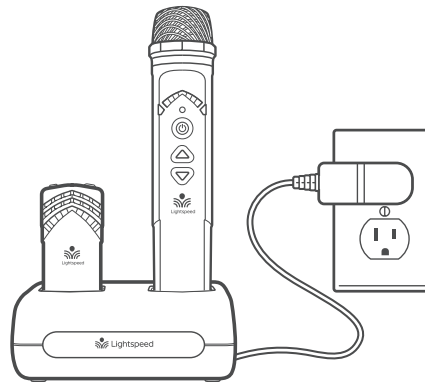

CONNECT CRADLE CHARGER

Plug power cord into the cradle charger and then plug the AC end into an electrical outlet.

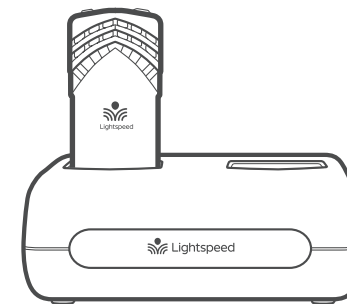

CHARGE MICROPHONE

Place the microphone into the cradle charger. The LED battery status light will glow red indicating charging has started.

The battery status light will glow green to indicate that charging is complete and a full charge has been reached.



PLEASE NOTE: The components are paired, together at the factory. Please keep all components together as a system. Moving them from one system, or room, to another will result in the need to re-pair.

Operating the Microphone

Once the microphone is charged, follow these steps to set it up for use.

1. Remove the microphone from the cradle charger. The Flexmike is worn by connecting the magnetic clasps behind your neck. Adjust the lanyard so the top of the Flexmike is at the collarbone.
2. The microphone will automatically power on and mute when it is removed from the charger. This will automatically power on the 975 as well.
3. The microphone volume is set at the factory to the mid point.
4. While speaking in a normal voice, fine-tune the microphone volume by adjusting the up or down buttons on the microphone.
 - Your voice should be clearly heard by another person on the other side of the room.
 - You should barely be able to hear your own voice.
 - There should not be any audio “feedback” or squealing outside of 2-3 feet (if there is, turn the volume down slightly).
5. Once initial volume level is set, walk around the room and listen for overall audio quality.
6. If further fine-tuning is required, you may need to adjust the Tone Control on the front of the 975.

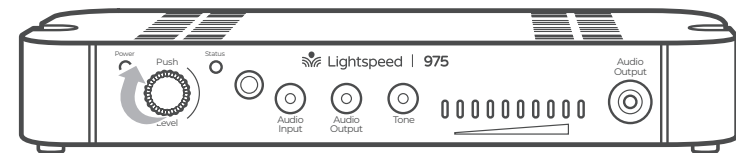
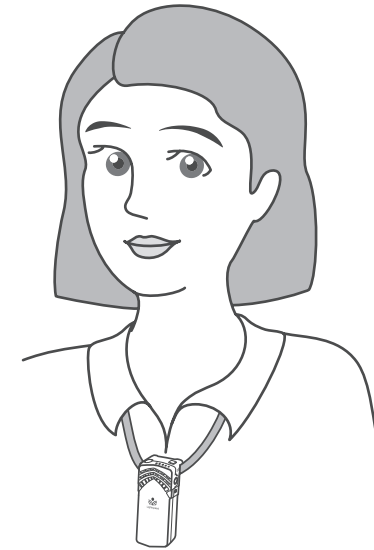

REMEMBER: This equipment is designed to supplement and distribute the user’s voice so they are able to speak in a conversational tone. Having the volume set too high will result in feedback and listener fatigue.

Audio Integration

The next step in setting up your system is to connect it to the other multimedia devices in your classroom. You may have a computer, displays a visual projection system or other devices. Below are instructions on how to integrate displays, DVD or computer directly into the amplifier.

1. Ensure the amplifier power is switched off and the AUDIO IN volume control is turned all the way down.
2. Connect the appropriate RCA or 3.5mm audio cable (not included) from the audio source into one of the input jacks on the rear panel of the amplifier.
3. With both the amplifier and the audio source power on, adjust the corresponding volume control on the amplifier until the desired level is achieved.

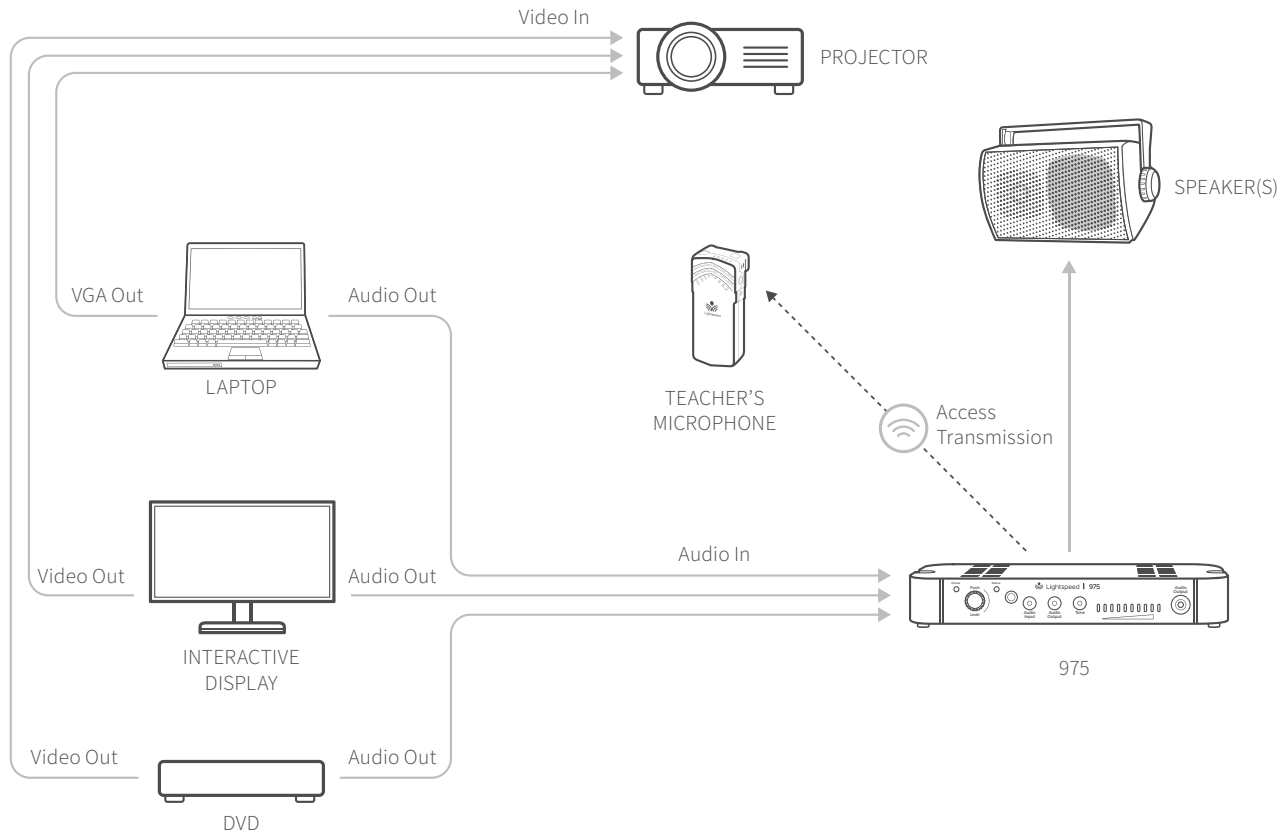

INSTALLING OPTIONAL EQUIPMENT

Life Safety Solutions

PAGEFIRST

The PageFirst™ function passively detects the audio signal of a page coming through the PA system. As an audio signal is sent to the PA speaker, the PageFirst™ detects that signal and immediately mutes the 975.

The following components are included when the PageFirst option is purchased as an add-on:

- PageFirst sensor clip with wire pigtail (PFSC50)
- 50' length of shielded plenum wire*

LOCATE PAGING SPEAKER AND SENSOR CLIP

If possible, the paging sensor should be hung around the lead wires that are connected directly to the speaker. If it is a sealed ceiling speaker where only the 70-volt wire is accessible, connect to the exposed 70-volt wires.

1. Locate the paging speaker in the classroom.
NOTE: PageFirst does not work with telephone or IP-based intercom systems.
2. Locate the PageFirst sensor clip. This clip is designed to hang around the wire connected to the paging speaker.

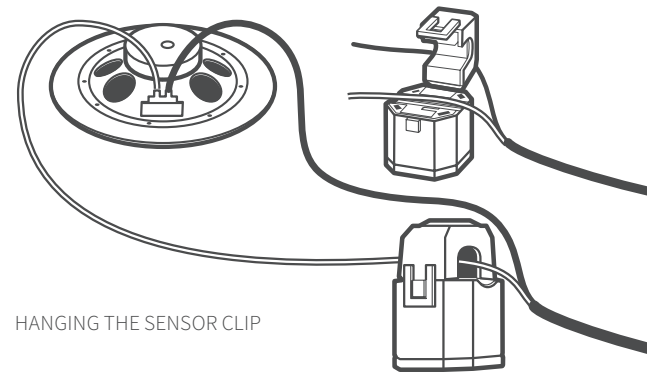

CONNECTING SENSOR TO SPEAKER WIRE

1. Gain access to the back of the speaker either up in the ceiling or on the wall.
NOTE: There is no need to disconnect any wires.
2. Unclip and open the top loop of the PageFirst sensor. Hang it around one of the lead wires connected to the paging speaker and clip it back together.



Take precautions as necessary to prevent and guard against electromagnetic and electrostatic noise interference. Unshielded and / or poorly shielded cable, multiple ground paths and improper grounding may all contribute to the production of a low frequency noise which could result in the PageFirst clip muting incorrectly.

CONNECT PAGEFIRST SENSOR TO AMPLIFIER

The sensor needs to be hard-wired back to the amplifier.

1. For 975, insert the PageFirst wire into the left side of the six pin euro-block connector on the amplifier. Insert the connector into the back of the 975.
2. Route the wire from the amplifier to the paging speaker. NOTE: when routing wire, make sure to secure to the building structure, as electrical and building codes require.
3. If the system mutes during times when a page is not being broadcast, turn the sensitivity down by turning the ADJ knob counterclockwise, and test again.

TESTING PAGEFIRST

A page will need to be broadcast through the system to verify PageFirst is properly sensing the audio signal.

1. Turn on the system and begin speaking.
2. Broadcast a page through the central paging system.
3. The system should mute as the page is broadcast. When the broadcast is over, the system should amplify the mic as normal.
4. While walking around the room, continue talking into the microphone. Verify that the system is not muting during times there is no page being broadcast.

ADJUSTING THE SENSITIVITY

1. The sensitivity adjustment (labeled “ADJ”) is pre-set to the 12 o’clock position. This should be the appropriate setting for the majority of installations.
2. If the system does not mute while the page is being broadcast, turn the sensitivity adjustment up by turning the ADJ knob clockwise and test again.

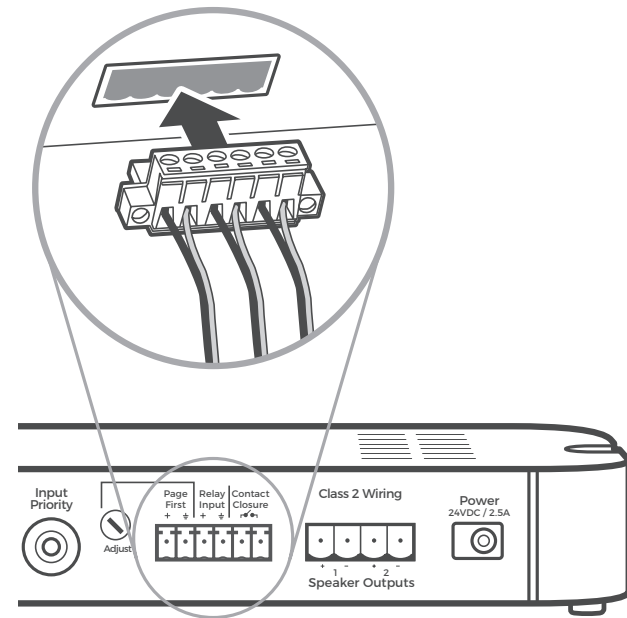

CONNECTING PAGEFIRST TO AMPLIFIER



NOTE: The PageFirst function works via current induction. The above instructions represent the most common method to achieve sufficient induction. If sufficient induction is not achieved to trigger this function, please contact Lightspeed regarding alternate installation methods.

Life Safety Solutions

RELAY INPUT

The 975 contains an input connection to detect a signal from Fire Alarm, IP Paging System or other device. When triggered, audio from the 975 is muted to ensure emergency alerts from external systems can be heard.

The Relay Input can be triggered with either DC voltage between .5V and 24V from a powered relay switch or a resistive short from a fire alarm system.

DC VOLTAGE

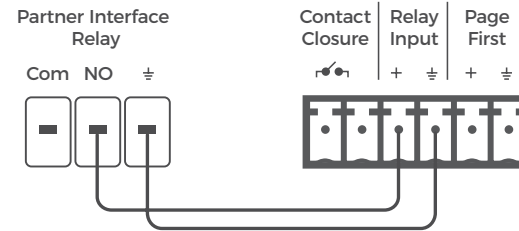

RESISTIVE SHORT

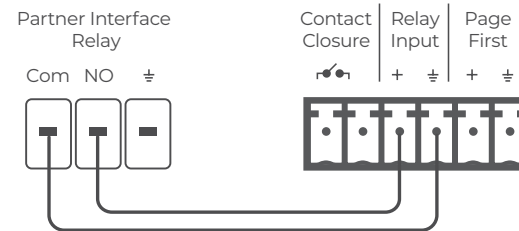

CONTACT CLOSURE

If your building is equipped with an alert notification system, teachers can use the Flexmike microphone to send an alert.

This activates the contact closure function on the 975, which external systems use to perform a prescribed action, such as notifying the appropriate parties of a classroom alert.

The Contact Closure is a normally open relay that can be closed by pressing the up and down volume buttons at the same time for 3 seconds on the Flexmike.

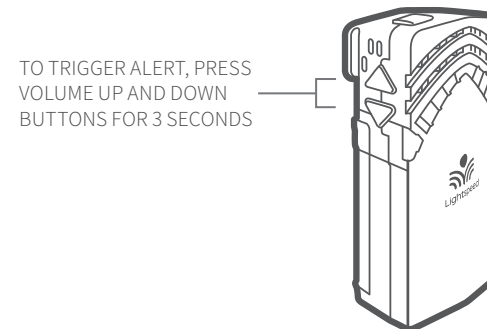



Optional Activate Charging Station Set-Up

1. DETERMINE SET-UP LOCATION

The Activate Station charges the microphone(s) and also wirelessly connects audio to the instructional audio system and your mobile device. Set it up in a convenient place near a power source that is highly accessible for both teachers and students. If plugging in multimedia audio sources, it should be located in close proximity to minimize cable runs.

Key considerations:

- Accessible for daily charging of all components
- Do not place in a fully enclosed metal cabinet

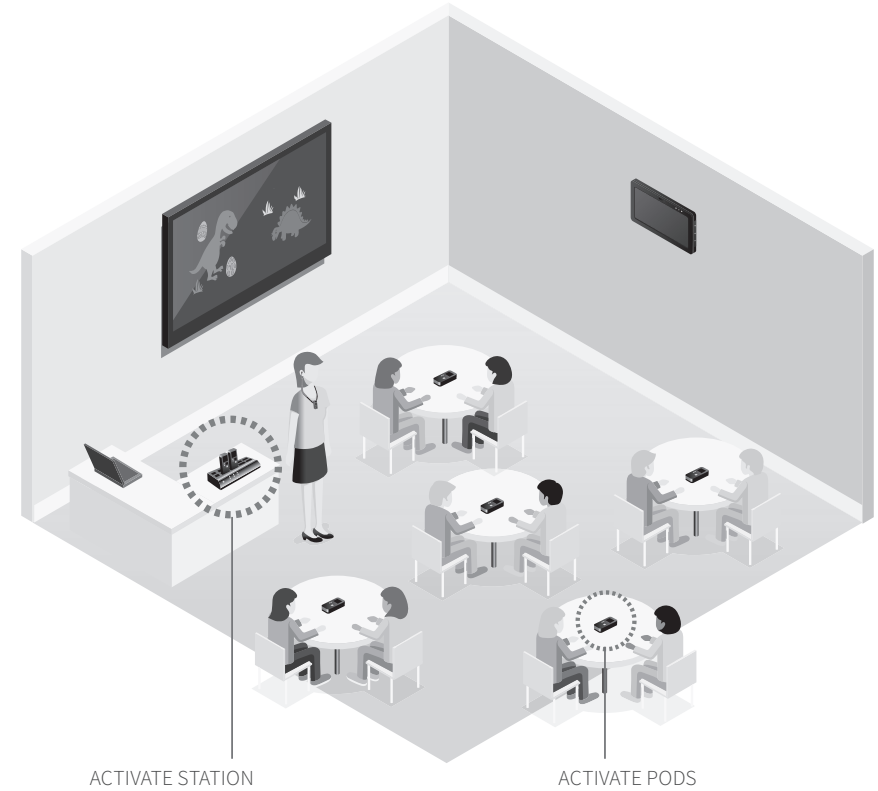
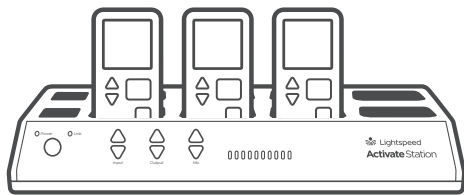

2. PLUG IN THE ACTIVATE STATION

1. Locate the 24V power supply and power cable.
2. Connect the AC power cord into the DC power supply.
3. Insert the DC connector into the Power jack on the back.
4. Plug the AC power cord into an electrical outlet.
5. The white power light on the front of Activate Station will glow.
6. The green link light will begin blinking as it searches for its paired classroom base station.

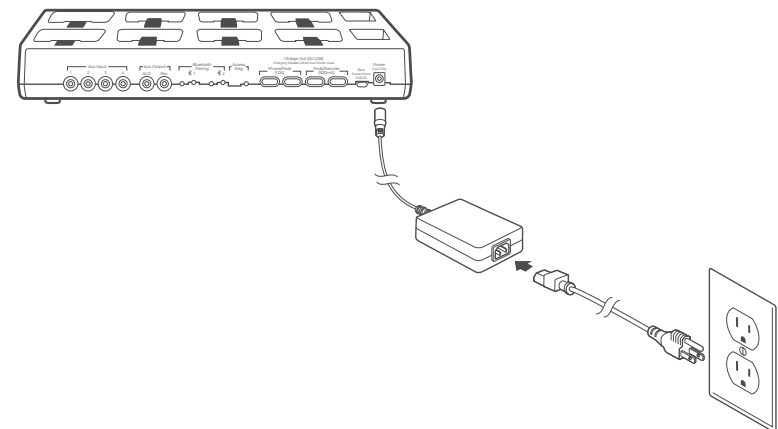

3. PLACE THE MICROPHONES IN THE ACTIVATE STATION

Prior to full operation, the microphones should be fully charged (5-6 hours) to ensure optimum performance. In most cases, there should be enough battery life for initial setup and testing.

1. Insert the microphone(s) into the Activate Station.
2. The microphone(s) will power on and battery status light will turn red to indicate normal charging. When fully charged, it will turn green. The white microphone 1 or 2 light will blink for several seconds as it establishes a link, then turns solid.

NOTE ON PAIRING: If your Activate System was purchased together with the 975, all components were paired together at the factory. If the system is being added to an existing Lightspeed audio system, please refer to the Registration Procedure at www.lightspeed-tek.com/accessregistration for proper pairing instructions.

The components are paired and ready for operation when:

- Microphone(s) has a solid white #1 or #2 light
- Activate Station has a solid green link light

NOTE: Refer to Daily Use Guide for operation.

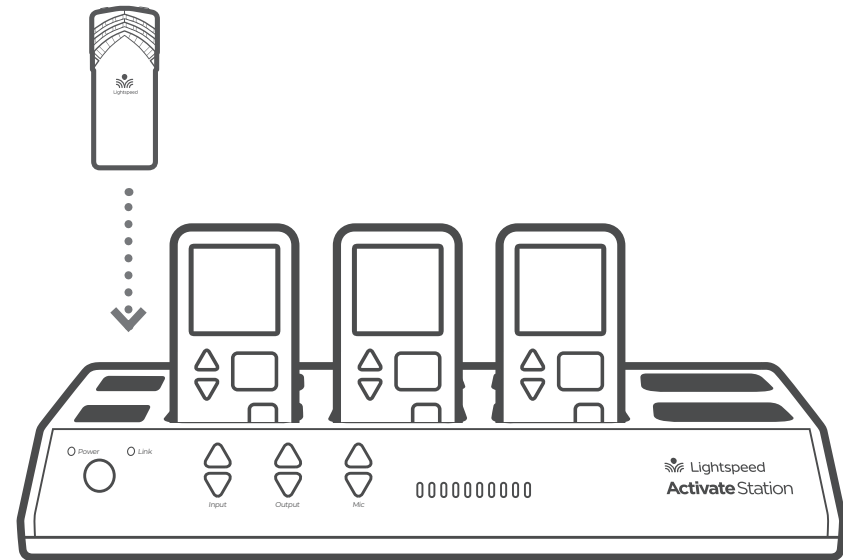



4. VOLUME ADJUSTMENT FOR THE ACTIVATE STATION

The Activate Station can be used as the primary volume control for the audio sources you've connected.

1. Connect the audio source(s) to the Activate Station using the 3.5mm cables provided.
2. Set the audio source volume to provide sound through the classroom speaker.
3. Use the Activate Station Audio In volume control to increase or decrease the sound level.

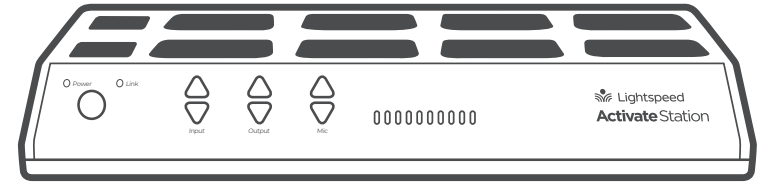

NORMALIZING AUDIO SOURCE VOLUME LEVELS

Use the Activate Station as the master audio volume control for the classroom. When two or more audio sources are connected, you will need to normalize volume settings by setting all connected audio sources to the same sound level while leaving the Activate Station Audio In volume control set to its center setting. The Activate Station is an audio mixer using a master volume control to adjust the volume of all audio sources at once. Use the following procedure to set audio source volumes:

1. Connect the multimedia audio sources to the Activate Station using the 3.5mm cables provided.
2. Set the Audio In volume control on the Activate Station to its center position.
3. Turn on an audio source that does not have an accessible audio level control. (DVD player)
4. Adjust the Activate Station Audio In volume control so the audio level playing through the speaker is appropriate for the classroom.
5. Turn off the first audio source.
6. Turn on the second audio source. Use its volume control to balance the audio output to the same audio level played through the speaker as the first source.
7. Repeat steps 5 and 6 for the remaining audio sources.
8. Now, the Activate Station's Audio In volume can be used to increase or decrease the volume level for all audio sources as desired.

5. OPTIONAL ACTIVATE AUDIO INTEGRATION

The Activate Station is designed to integrate with the 975 and multiple audio sources, allowing other instructional technologies to be clearly heard throughout the classroom.

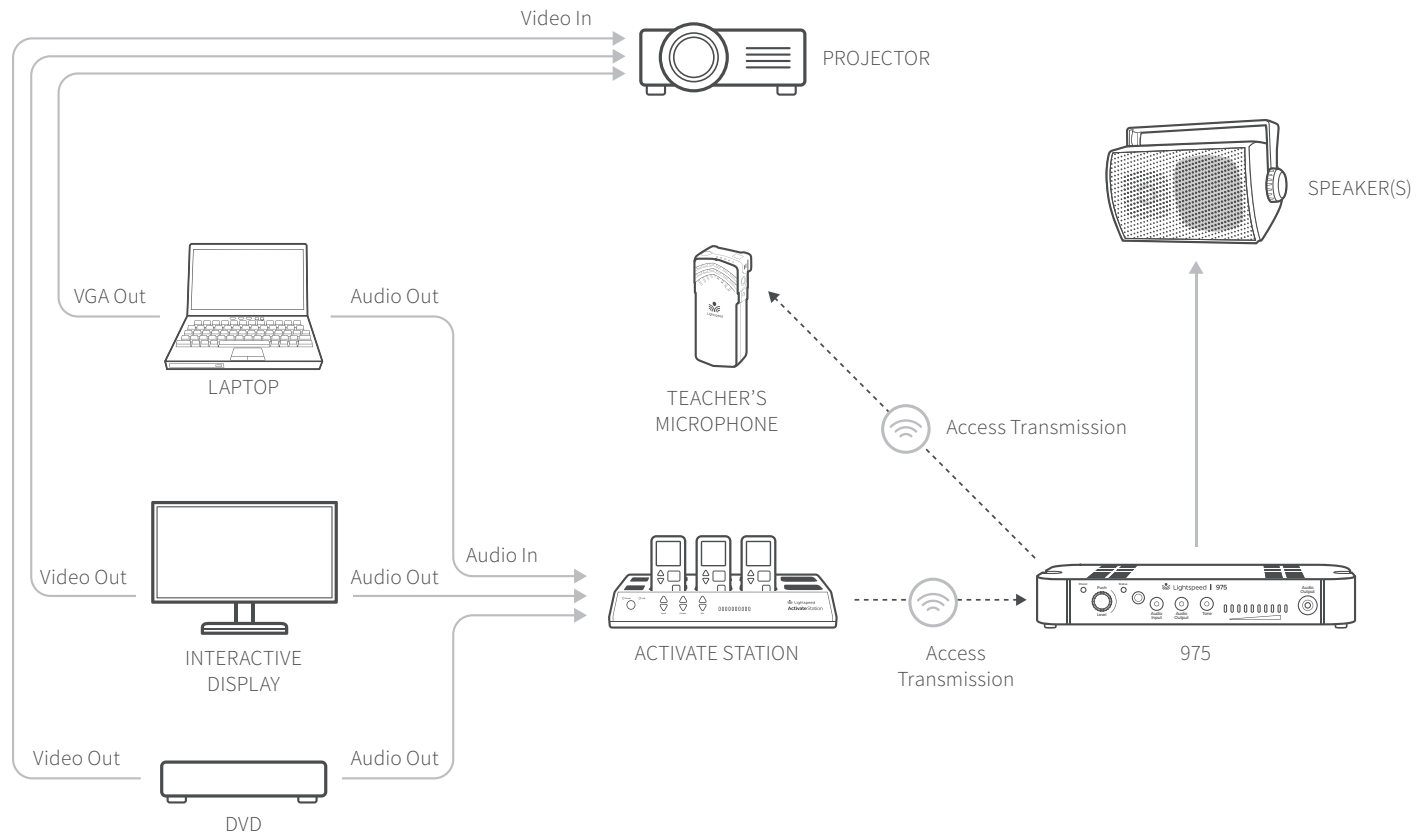

NOTE ON INTEGRATION: If the Activate Station is not included in installation, a 3.5mm audio cable may be connected from the audio source to the audio input on the back of the 975. Take precautions as necessary to prevent and guard against electromagnetic and electrostatic noise interference. Long cable runs, unshielded and / or poorly shielded cable, multiple ground paths and improper grounding may all contribute to the production of a low frequency hum. In most cases a ground loop isolator (not provided) placed in line will attenuate or possibly eliminate the hum.

Media Connector Set-Up

1. DETERMINE SET-UP LOCATION

- Choose a location for the Media Connector that is convenient to the classroom audio sources and power supply.
- The Media Connector can be placed on a counter or wall mounted, 3-6 feet off of the floor to allow for good transmission.
- If plugging in multimedia audio sources, it should be located in close proximity to minimize cable runs.
- **Note:** Do not place in a fully enclosed metal cabinet

2. WALL MOUNTING THE MEDIA CONNECTOR

- Find a location on the wall that is near the computer or other equipment that will be connected to the Media Connector.
 - Power for the Media Connector must be within 6 ft of this location.
1. Hold Media Connector up to the wall and ensure that it is level. Mark the mounting holes with a pencil. The back of the Media Connector that contains the inputs may be mounted in any position that is desirable.
 2. For sheetrock walls, use screw-in sheetrock anchors and screws (not supplied) to secure the Media Connector to the wall. It is best to drill a 1/4" pilot hole at the two mounting locations before inserting the anchors.
 3. Once the anchors are installed, place the Media Connector over the mounting anchors and insert the provided screws through the mounting holes and into the anchor.
 4. If walls are concrete or cinder block, appropriate mounting hardware should be purchased locally.

3. CONNECT THE POWER SUPPLY

1. Connect the USB power supply to the USB port on the Media Connector.
2. Plug the USB power supply into an electrical outlet or plug the cable into a computer USB port.
3. Press and hold the power-on button located on the front of the Media Connector to power on and power off the unit.

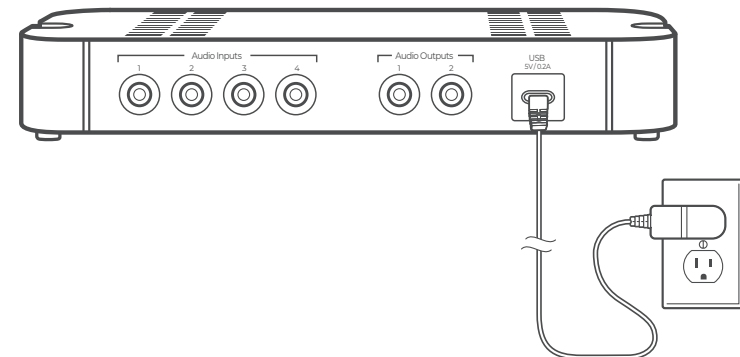
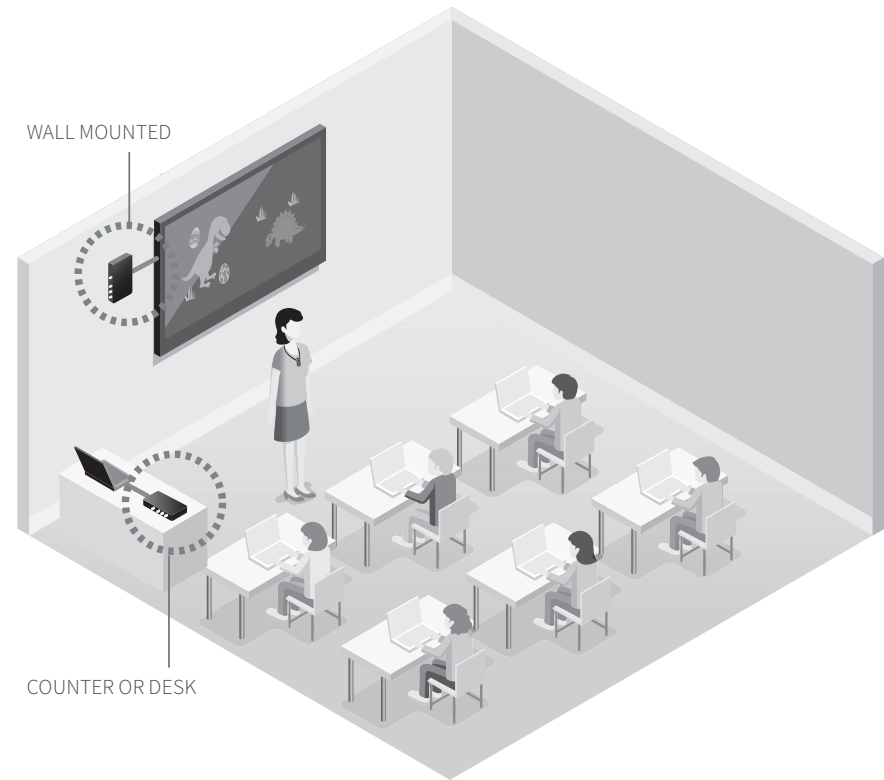

4. VOLUME ADJUSTMENT FOR THE MEDIA CONNECTOR

The Media Connector can be used as the primary volume control for the audio sources to be connected.

1. Connect the audio source(s) to the Media Connector using the 3.5mm cables provided..
2. Use the Media Connector Audio In volume control to increase or decrease the sound level.

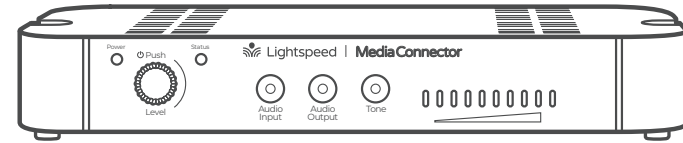

NORMALIZING AUDIO SOURCE VOLUME LEVELS

NOTE: When Media Connector is powered on and paired to 975, it locks out Master Volume and Tone controls on the 975.

Use the Media Connector as the master audio volume control for the classroom. When two or more audio sources are connected, you will need to normalize volume settings by setting all connected audio sources to the same sound level while leaving the Media Connector Audio In volume control set to its center setting. The Media Connector is an audio mixer using a master volume control to adjust the volume of all audio sources at once. Use the following procedure to set audio source volumes:

1. Connect the multimedia audio sources to the Media Connector using the 3.5mm cables provided.
2. Set the AUDIO IN volume control on the Media Connector to its center position.
3. Turn on an audio source that does not have an accessible audio level control. (DVD, mobile device or computer).
4. Adjust the Media Connector Audio In volume control so the audio level playing through the speaker is appropriate for the classroom.
5. Turn off the first audio source.
6. Turn on the second audio source. Use its volume control to balance the audio output to the same audio level played through the speaker as the first source.
7. Repeat steps 5 and 6 for the remaining audio sources.

8. Now, the Media Connector's Audio In volume can be used to increase or decrease the volume level for all audio sources as desired.

USB AUDIO INPUT INTERFACE

- To disable USB interface:

1. Remove power from Media Connector.
2. Press and hold Audio Out button while powering Media Connector back on.
3. USB interface is set to disable.
4. Status light will turn white to indicate USB is disabled.
5. Reboot Media Connector by removing and plugging in power supply.

- To enable USB interface:

1. Remove power from Media Connector.
2. Press and hold Audio Out button while powering Media Connector back on.
3. USB interface is set to enable.
4. Status light will turn blue to indicate USB enabled.
5. Reboot Media Connector by removing and plugging in power supply.



NOTE ON PAIRING: The 975 and Media Connector are paired together at the Lightspeed factory as required for proper operation. If paired components are separated and swapped during the installation process, they must be re-paired. Please refer to the registration instructions at www.lightspeed-tek.com/accessregistration.

5. OPTIONAL MEDIA CONNECTOR AUDIO INTEGRATION

The Media Connector is designed to integrate with the 975 and multiple audio sources, allowing other instructional technologies to be clearly heard throughout the classroom.

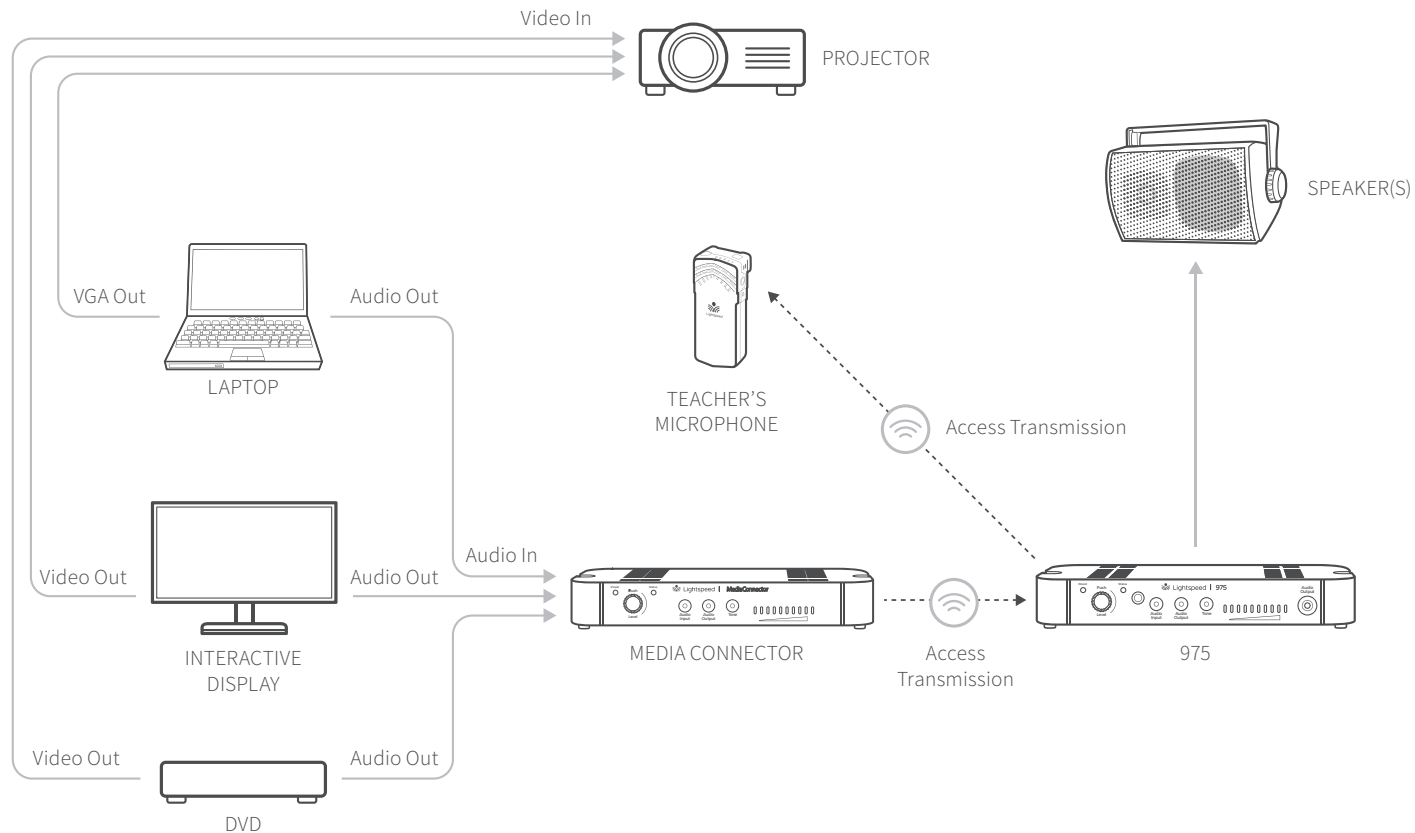

NOTE ON INTEGRATION: If the Media Connector is not included in installation, a 3.5mm audio cable may be connected from the audio source to the audio input on the back of the 975. Take precautions as necessary to prevent and guard against electromagnetic and electrostatic noise interference. Long cable runs, unshielded and / or poorly shielded cable, multiple ground paths and improper grounding may all contribute to the production of a low frequency hum. In most cases a ground loop isolator (not provided) placed in line will attenuate or possibly eliminate the hum.

TROUBLESHOOTING

COMMON PROBLEMS AND SOLUTIONS

Most problems are related to low battery power. Use fully-charged batteries in good condition.

BATTERY CHECK

- Confirm batteries are charged each night. A red light on the battery status light indicates a low battery.
- Make sure the microphones obtain a full charge. A full charge takes 5-6 hours.
- When charging transmitter, ensure the red charging light turns on. The green light will turn on when a full charge is reached.

PROBLEM: Low volume or feedback

SOLUTION: Follow these steps to eliminate low volume or feedback.

- Adjust the volume level on the microphone.
- Check microphone volume level on the amplifier. If the volume is too high, feedback will occur. Adjust accordingly.
- Check input volume level on the amplifier. If the volume is too high, feedback will occur. Adjust accordingly.

PROBLEM: No sound from speaker and wireless components

SOLUTION: Follow these steps to produce sound from amplifier.

- Confirm that the white POWER light located on the front panel of the amplifier is on.
- Confirm the microphone is powered on and linked to the amplifier. The mic 1 or 2 status light will be white on the microphone indicating the microphone is linked.
- Confirm that the microphone is turned on. There will be a solid blue light on the top of microphone to indicate it is powered on and ready.
- Confirm that microphone is not muted. A solid white light on the top of microphone will indicate it is muted.

- Check speaker connections on the amplifier. Make sure the cables are properly connected (see page 31 of this manual for more information).
- Check volume level of amplifier. Make sure that the microphone volume level on the 975 is not turned down all the way. Slowly turn up the volume level on the microphone while talking into the microphone.
- If an Activate Station or Media Connector is paired with the 975, make sure that the volume level of the Activate Station or Media Connector is not turned down all the way. Slowly increase the volume level while talking into the microphone.

If you review these instructions and still have questions, call Lightspeed Technical Services at 800.732.8999, 5am – 5pm, PST. Customers outside the U.S. should contact their local reseller.



TIPS TO OBTAIN OPTIMUM AUDIO PERFORMANCE

- **Speak in a natural voice.** A normal conversational speech level will provide an adequate signal. It is not necessary to increase the intensity of your voice—the audio system provides adequate amplification above ambient room noises.
- **Avoid wearing jewelry that may rub or bump** against the microphone.
- **Mute the microphone during private conversations** with a student, parent, or other classroom visitor. You can tell the mic is muted when the light turns white.
- **Recharge microphones each night.** When recharged nightly, operating time (actual usage) for the microphones will last through a typical school day.



83-975-A



Dedicated to Access for all

We create instructional audio and video solutions that unlock student access to learning opportunities and give teachers meaningful insights into moment-by-moment learning.

11509 SW HERMAN ROAD
TUALATIN, OREGON 97062
TOLL FREE: 800.732.8999
PHONE: 503.684.5538
FAX: 503.684.3197
LIGHTSPEED-TEK.COM

