

Topcat®

Instructional Audio System

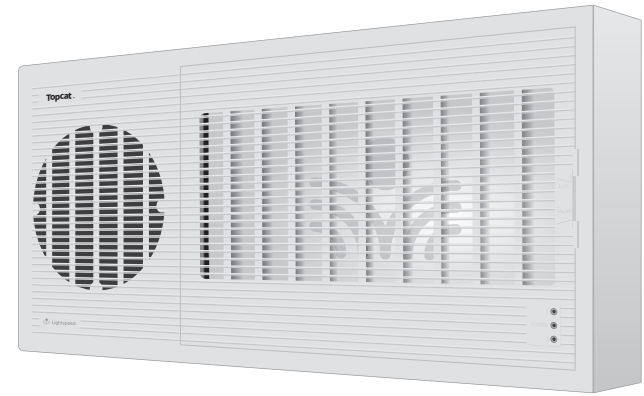

Installation Guide





Important Safety Instructions

1. Do not use the apparatus near water.
2. Clean only with dry cloth.
3. Do not block any ventilation openings.
4. Do not install near any heat sources such as radiators, heat registers, stoves, or other apparatus (including amplifiers) that produce heat.
5. Do not defeat the safety purpose of the polarized or grounding-type plug.
A polarized plug has two blades with one wider than the other. A grounding-type plug has two blades and a third grounding prong. The wide blade or the third prong is provided for your safety. If the provided plug does not fit into your outlet, consult an electrician for replacement of the outlet.
6. Protect the power cord from being walked on or pinched particularly at plugs, convenience receptacles, and the point where they exit from the apparatus.
7. Unplug this apparatus during lightning storms or when unused for long periods of time.
8. Refer all servicing to qualified service personnel. Servicing is required when the apparatus has been damaged in any way, such as power-supply cord or plug is damaged, liquid has been spilled or objects have fallen into the apparatus, the apparatus has been exposed to rain or moisture, does not operate normally, or has been dropped.
9. When the mains plug or appliance coupler is used as the disconnect device, it shall remain readily operable.
10. Please keep the unit in a good ventilation environment.
11. WARNING: To reduce the risk of fire or electric shock, do not expose this apparatus to rain or moisture.
12. Apparatus shall not be exposed to dripping or splashing and no objects filled with liquids, such as vases, shall be placed on the apparatus.
13. WARNING: Battery pack shall not be exposed to excessive heat such as sunshine, fire or the like.

Table of Contents

OVERVIEW

- 2 Important Safety Instructions
- 4 System Components and Unpacking
- 5 Optional Components

INSTALLATION

- 6 Installation Planning
- 6 Selecting Mounting Location
- 7 Topcat Ceiling Installation (U.S. & Canada)
- 9 Topcat Ceiling Installation (Outside U.S. & Canada)
- 12 Installing and Wiring Electrical Power
- 14 External Power Connection
- 15 Audio Input Cable Installation
- 16 Setup and Using the Flexmike
- 17 Charging the Flexmike

INSTALLING OPTIONAL EQUIPMENT

- 18 PageFirst Installation
- 21 Media Connector Set-Up
- 25 Audio Input Cable Installation
- 26 Safety Warnings and Certifications

TROUBLESHOOTING

- 28 Common Problems and Solutions
- 28 Tips to Obtain Optimum Audio Performance



OVERVIEW

System Components and Unpacking

The standard configuration includes:

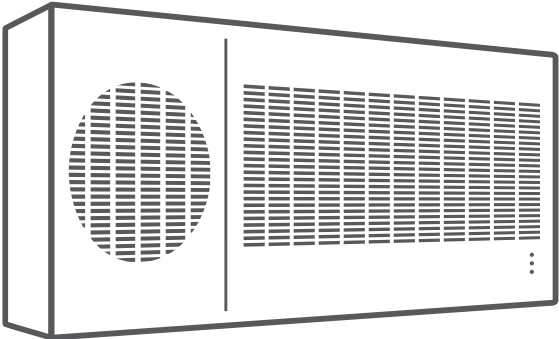

Topcat



Flexmike
Volume Control Microphone

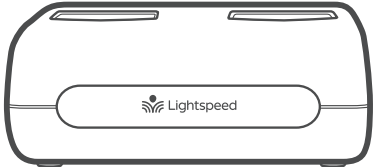

Microphone Cradle Charger
& Power Supply

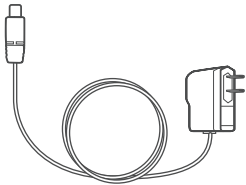

NOTE ON PAIRING: Topcat, microphone(s), and Media Connector or Activate Station are paired together at the Lightspeed factory as required for proper operation.

Optional Components

Optional equipment which may be part of your Topcat system:

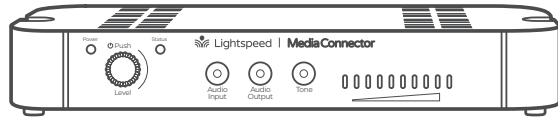

Media Connector
& Power Supply

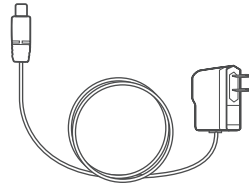

ShareMike
Handheld Microphone

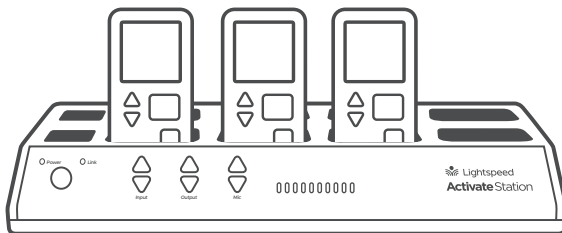

Activate Station
with Bluetooth

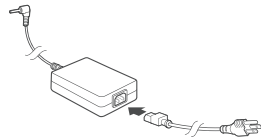

INSTALLATION

Installation Planning

Before beginning installation, make sure you have the necessary tools and materials on hand and that the area underneath the proposed Topcat location is cleared.

NOTE: Topcat is designed for installation in a 2' x 2' or 2' x 4' suspended ceiling grid (or 600mm x 600mm international ceiling grids). If you do not have this type of ceiling, please contact your local Lightspeed Territory Manager.

TOOLS AND MATERIALS

In addition to the contents of the Topcat system, you may need the following tools & materials:

- Flat blade screwdriver (small)
- Pliers
- Wire cutters
- Drill
- Utility knife
- Safety wire anchors
- Wire ties

SELECTING MOUNTING LOCATION

The Topcat is shipped ready to mount in a standard suspended ceiling grid. All hardware needed to secure the Topcat into the ceiling grid is provided. Additional hardware may be required if building structure tie-points are metal. A licensed electrician will need to provide necessary materials if Topcat is permanently connected to the building AC mains.

Topcat will distribute sound throughout a classroom of up to 1200 sq ft (112 sq m) with ceiling heights of 9 to 12 ft. The location of the Topcat is critical to ensure even sound distribution.

1. Identify the center of the listening area of the classroom for optimum location (Figure 1).
2. Select a ceiling tile that is free of fixtures (lighting, HVAC, etc.) nearest to the center point.
3. Remove the selected ceiling tile for Topcat installation.

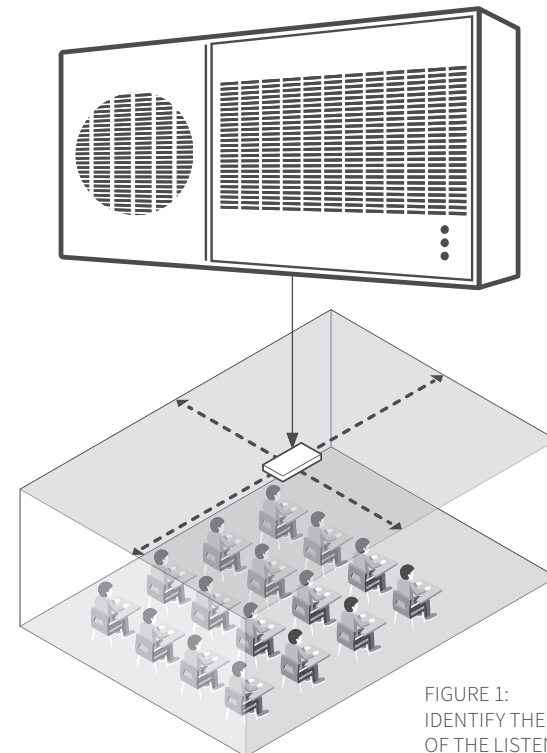

FIGURE 1:
IDENTIFY THE CENTER
OF THE LISTENING AREA

TOPCAT CEILING INSTALLATION (U.S. & CANADA)

The dimensions of Topcat are 1' x 2' and it is designed to fit into any standard 2' x 2' or 2' x 4' suspended ceiling tile grid.

1. The ceiling tile will need to be cut to accommodate Topcat.
2. Set the ceiling tile on a flat work surface with the patterned side facing down.
3. Using a straight edge, cut a 1' x 2' section from the ceiling tile, leaving a 1' x 2' section and a 2' x 3' section (Figure 2), or two 1' x 2' sections (Figure 4).

2' X 4' CEILING TILE

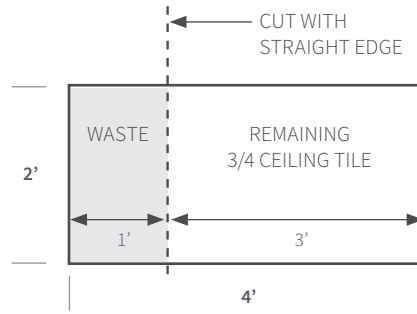

FIGURE 2:
CUT THE 2' X 4' TILE TO CREATE A 1' X 2'
SECTION AND A 2' X 3' SECTION

2' X 2' CEILING TILE

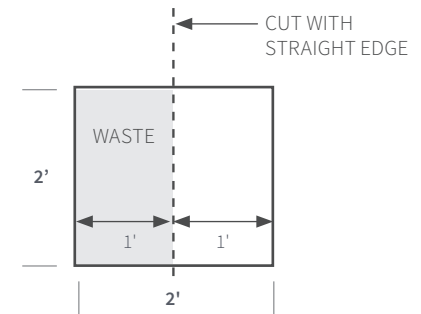

FIGURE 4:
CUT THE 2' X 2' TILE TO CREATE
TWO 1' X 2' SECTIONS

4. Locate the 2' ceiling grid T-bar provided. Locate the attachment slots in the existing ceiling grid and snap the new T-bar into place to create two openings to create a 1' x 2' and a 2' x 3' opening (Figure 3) or two 1' x 2' openings (Figure 5).

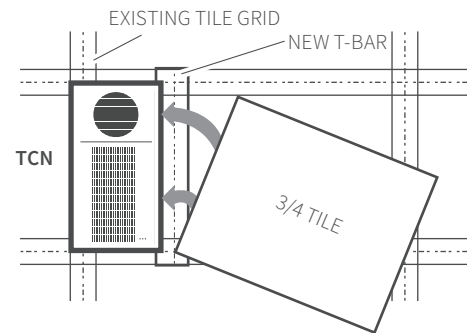

FIGURE 3:
SNAP THE T-BAR INTO PLACE TO CREATE A
1' X 2' OPENING AND A 3' X 2' OPENING

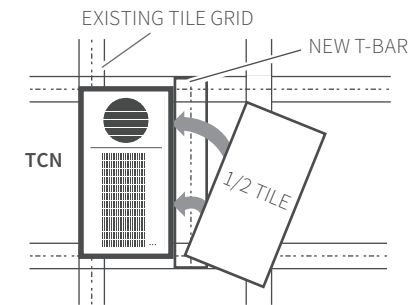
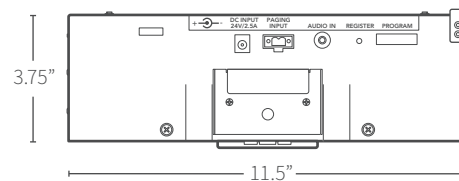
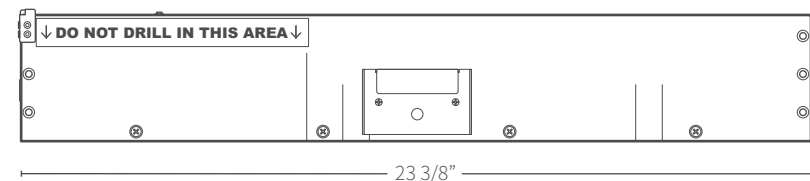

FIGURE 5:
SNAP THE T-BAR INTO PLACE TO
CREATE TWO 1' X 2' OPENINGS

5. Topcat dimensions



END



SIDE

SECURING TOPCAT (U.S. & CANADA)

To comply with Building Codes, the Topcat **MUST** be secured with two safety wires.

1. Install anchors (or eye screws if necessary) into the building structure.
2. Loop one end of the safety wire through the anchor (or eye screw), then twist it around itself at least five times (Figure 1). Repeat for second anchor.
3. Lift the Topcat up and lay it into the desired ceiling grid location.



CAUTION: Ensure that Topcat is stable on the grid rails with the side brackets hooked over the rails. If not stable, there could be a danger of it falling until safety wires are attached.

4. Loop the other end of the safety wire through one of the tabs on Topcat (located in opposite corners). Pull the wire through until it is taut and twist it around itself at least five times to secure Topcat. Cut off excess wire if needed.
5. When hard wiring AC power to Topcat, electrical codes require for Topcat to be attached to the ceiling rail. Utilizing existing holes on the vertical section of the ceiling rail (center of the hole to the base of the rail must be a minimum of 15mm) drill two screws on each 2' side of the Topcat. Drilling these screws into the designated areas of the Topcat chassis will not cause harm to the product (Figure 3).
6. Continue to page 12, Installing and Wiring Electrical Power.

NOTE: Do not drill in the area designated with yellow tape.

FIGURE 1:
LOOP THE SAFETY WIRE THROUGH TAB

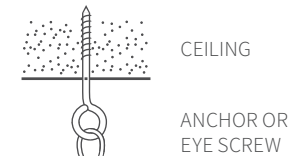

FIGURE 2:
PLACE TOPCAT INTO THE CEILING
GRID AND LOOP THE SAFETY WIRE
THROUGH BOTH TABS

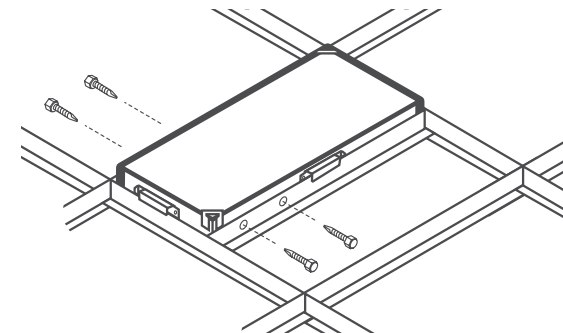
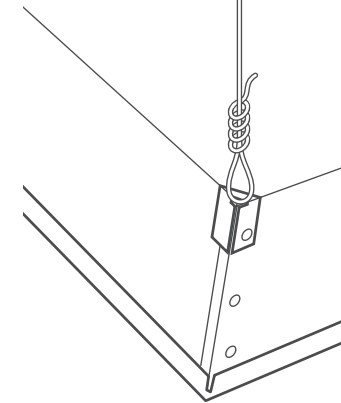

FIGURE 4:
DRILL SCREWS THROUGH CEILING RAIL INTO DESIGNATED AREAS OF TOPCAT

TOPCAT CEILING INSTALLATION (OUTSIDE U.S. & CANADA)

For 600mm x 600mm Ceiling Grid

Topcat has spacer brackets mounted on each of the four sides. With these brackets installed and the ceiling tile is cut in half, the Topcat will fit into a standard 2' x 2' suspended ceiling grid with an additional tile support. With the brackets removed, it will fit a 300mm x 600mm ceiling grid with an additional tile support (Figures 4 & 5).

Remove the spacer brackets from each of the four sides of the Topcat (Figure 1, next page).

NOTE: If your ceiling grid is any other dimension than mentioned above, contact your local Lightspeed Representative.

2' X 4' CEILING TILE

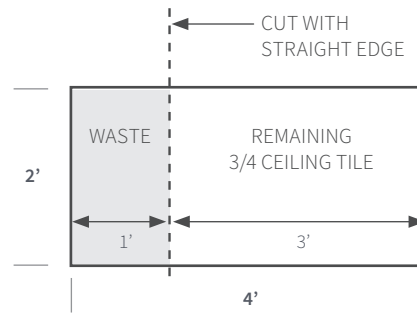

FIGURE 1
CUT THE 2' X 4' TILE TO CREATE A 1' X 2' SECTION AND A 2' X 3' SECTION

2' X 2' CEILING TILE

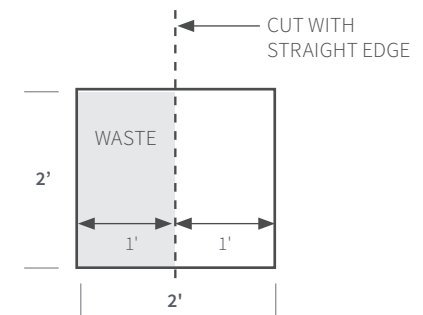

FIGURE 3:
CUT THE 2' X 2' TILE TO CREATE TWO 1' X 2' SECTIONS

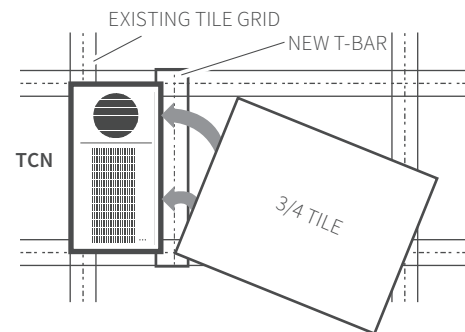

FIGURE 2
SNAP THE T-BAR INTO PLACE TO CREATE A 1' X 2' OPENING AND A 3' X 2' OPENING

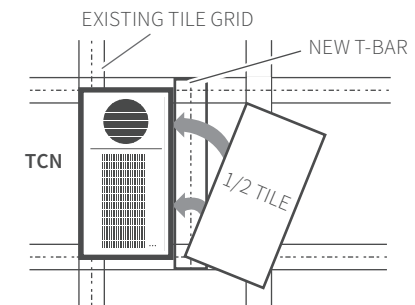

FIGURE 4:
SNAP THE T-BAR INTO PLACE TO CREATE TWO 1' X 2' OPENINGS

SECURING TOPCAT (OUTSIDE U.S. & CANADA)

To comply with Building Codes, the Topcat *MUST* be secured with two safety wires and to the ceiling grid with four screws.

1. Remove the spacer brackets from each of the four sides of Topcat (Figure 1).
2. Locate the safety wire. The safety wire needs to be permanently attached to the solid building structure above.
3. Cut the safety wire in half.
4. Install anchors (or eye screws if necessary) into the building structure.
5. Loop one end of the safety wire through the anchor (or eye screw), then twist it around itself at least five times (Figure 2). Repeat for second anchor.
6. Lift the Topcat up and lay it into the desired ceiling grid location.

CAUTION: Ensure that Topcat is stable on the grid rails. If not stable there could be a danger of it falling until safety wires are attached.

7. Loop the other end of the safety wire through one of the tabs on Topcat (located in opposite corners). Pull the wire through until it is taut and twist it around itself at least five times to secure Topcat. Cut off any excess wire if needed (Figure 3).

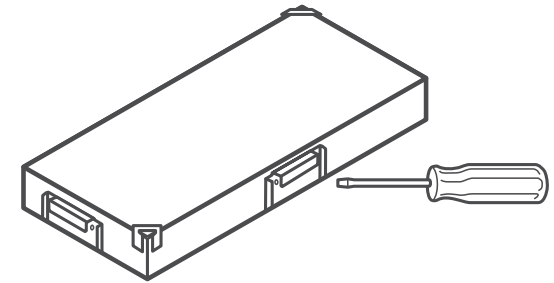

FIGURE 1:
REMOVE SPACER BRACKETS

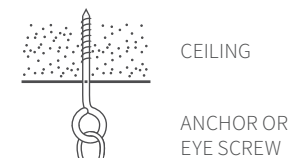

FIGURE 2:
LOOP THE SAFETY WIRE THROUGH TAB

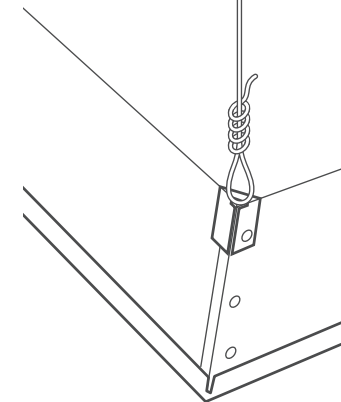

FIGURE 3:
PLACE TOPCAT INTO THE CEILING
GRID AND LOOP THE SAFETY WIRE
THROUGH BOTH TABS

SECURING TOPCAT (OUTSIDE U.S. & CANADA)

8. Locate the four self-drilling sheet metal screws (use #8 X 3/4" only).
9. Utilizing existing holes on the vertical section of the ceiling rail (center of the hole to the base of the rail must be a minimum of 15mm, drill two screws on each 0.6m side of Topcat (Figure 6).

NOTE: Do not drill in the area designated with yellow tape.

10. When hard wiring AC power to Topcat, electrical codes require Topcat to be attached to the ceiling rail.

NOTE: Drilling these screws into the designated areas of Topcat chassis will not cause harm to the product (Figure 7).

11. Continue to page 12, Installing and Wiring Electrical Power.

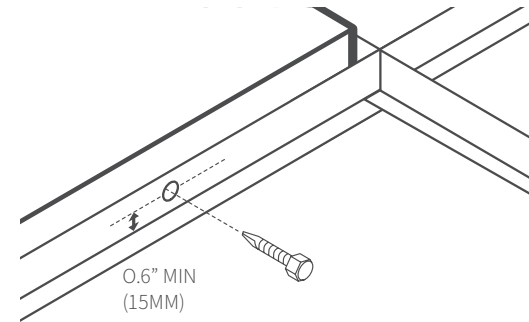

FIGURE 6:
DRILL SCREWS INTO THE CEILING RAIL

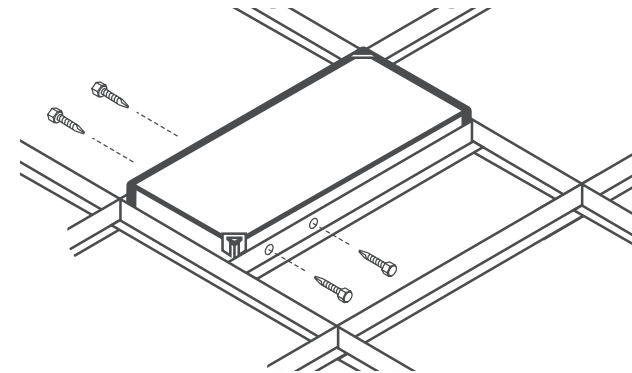

FIGURE 7:
DRILL SCREWS THROUGH CEILING GRID INTO DESIGNATED AREAS OF TOPCAT

INSTALLING AND WIRING ELECTRICAL POWER

There are two methods of providing power for the Topcat.

1. **New Construction Installations:** Connect directly to the building's AC mains.
2. **Retrofit installations:** Wire to the building mains or order the optional extension cable (*Part #DCPEX-NA in U.S. and Canada; DCPEX-INT outside U.S. and Canada*).

SUPPLY POWER TO THE SELECTED LOCATION

WARNING! USE A LICENSED ELECTRICIAN FOR POWER CONNECTIONS.

The Topcat System uses standard 100 – 240VAC power. Obtain the services of a licensed electrician when supplying and connecting power to the Topcat chassis. Be sure electrical installation complies with local building codes. Improperly installing and / or connecting power to the system may result in EQUIPMENT DAMAGE, serious INJURY and / or DEATH.

When routing power to Topcat, avoid interference with lighting and other noise possibilities.

CAUTION: These servicing instructions are for use by qualified service personnel only. To reduce the risk of electric shock, do not perform any servicing other than that contained in the operating instructions unless you are qualified to do so.

Wire AC power to Topcat as follows:

1. Turn off the circuit at the main breaker. The all-pole main breaker shall be incorporated in the electrical installation of the building. Using copper wire attach the electrical wiring to the Topcat ceiling module as shown.
2. Find the power conduit hole on the Topcat back can and remove the plastic plug. Insert the mains electrical wire through the hole (Figure 1).
3. Open the front panel door on Topcat by sliding the door toward the end of Topcat to disengage the lock (Figure 2).

NOTE: Be careful not to damage flat speaker panel.

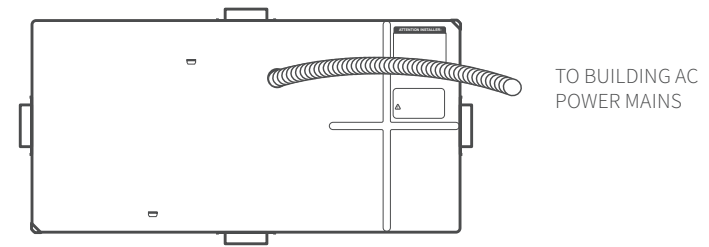

FIGURE 1

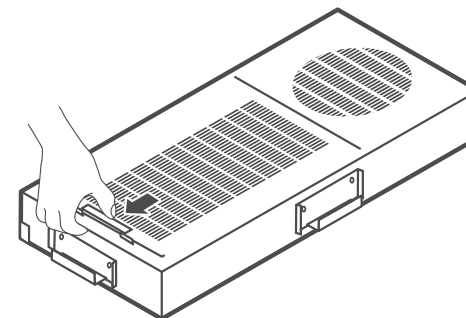
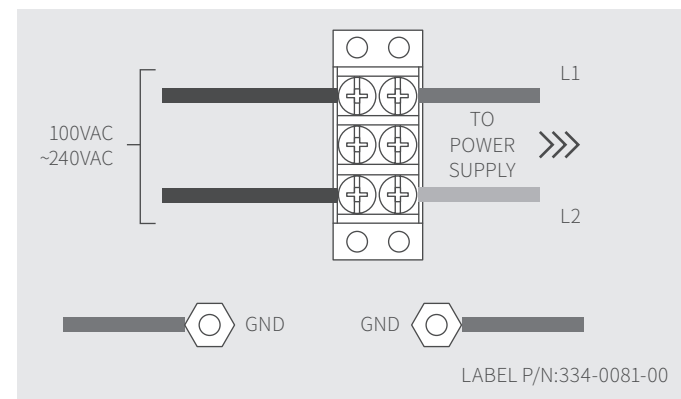
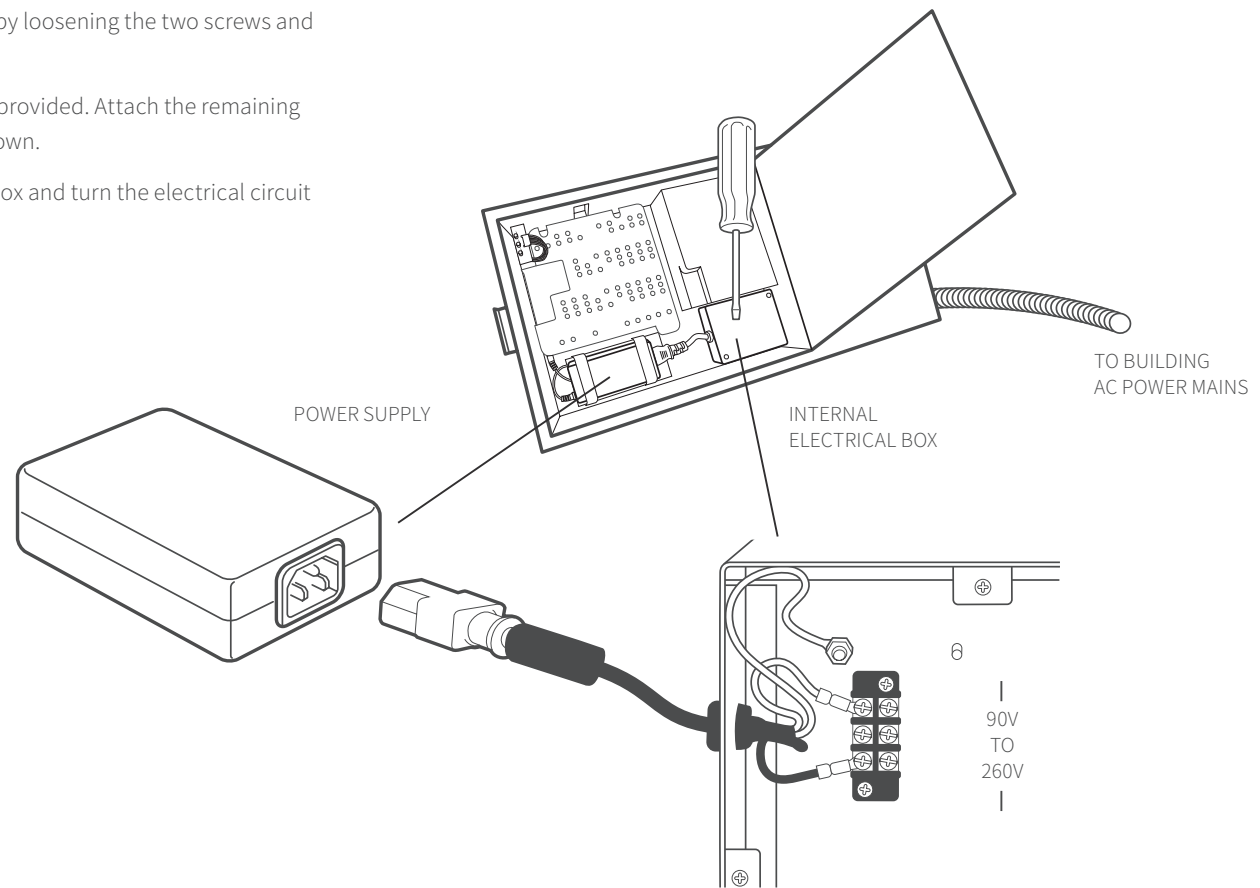

FIGURE 2

INSTALLING AND WIRING ELECTRICAL POWER CONT'D

4. Remove the lid to the internal electrical box by loosening the two screws and sliding the lid out (Figure 3).
5. Attach the ground wire to the grounding lug provided. Attach the remaining two wires to the terminal block screws as shown.
6. Replace the cover on the internal electrical box and turn the electrical circuit back on at the main breaker.



EXTERNAL POWER CONNECTION

When electrical AC power is not available above the ceiling for installation with Topcat, there is an alternative method for supplying power to Topcat.

There are two DC power connectors for connecting power to Topcat. Both connectors perform the same function. Use the internal DC power connector located on the amplifier module when AC power is connected directly to Topcat. **Use the 24V 2.5 amp port located on the outside of Topcat when using the optional DC extension cable:**

1. Remove the factory installed 24V 2.5 amp power supply by unstrapping the velcro holding it in place. Disconnect the AC power plug and the DC output cable. Then restrap the velcro strips and enclose the AC plug with the velcro to keep it in place. ***This AC plug should not touch the flat panel speaker when the door is closed.***
NOTE: The 24V power supply brick must be placed in the room below the suspended ceiling. Faceplates and electrical boxes should be provided by the installer as required.
2. Find the 50' DC extension cable and plug the female connector into the 24V 2.5 amp port on Topcat. Locate the protection bridge on the side of the Topcat and secure the extension cable to the protection bridge using a zip tie.

NOTE: The 50' DC extension cable is plenum rated, suitable for air handling spaces.

3. Route the DC extension cable across the ceiling and to the closest standard AC power outlet. Cable routing should follow all local electrical codes and installation procedures. (If the DC extension cable is to be run inside the wall, install a mud ring or electrical box in the wall close to the AC power outlet.

If the DC extension cable is run on the surface of the wall using wire molding, mount a surface-mount electrical box to house the connection of the DC extension cable and the power supply.

4. Plug the DC extension cable end of the 24V supply into the power extender cable. There must be a strain relief loop created and the loop attached to the barrel connection using a wire tie to secure the connection.
5. Plug the AC power cord into the power supply and into a standard AC outlet.
6. When power is applied to the Topcat, it will automatically power on.
7. After wiring electrical power is complete, close door securely by applying pressure outward on the tabs located on the main body of the Topcat. Then slide the door toward the middle of the unit and lock into place.

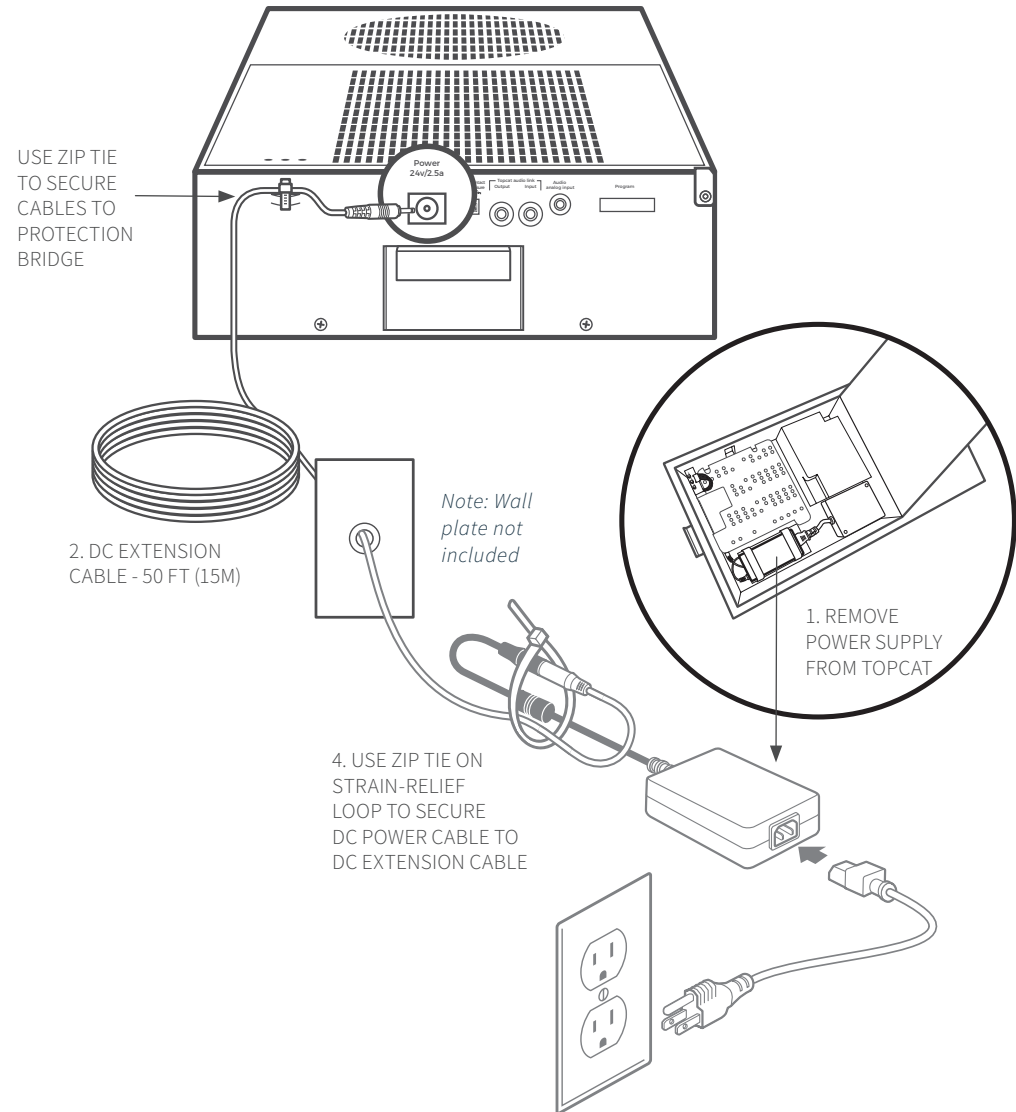
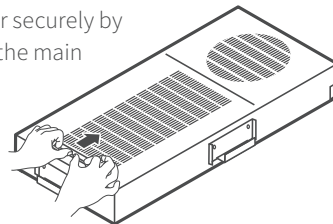

5. The power supply brick must be supported to prevent strain on the DC power connection. The power brick should either : 1) lay flat on the floor; 2) be positioned inside the recessed box often used for flat panel installations; 3) be secured via wire ties to an appropriate support such as the TV/Flat Panel mount or projector.

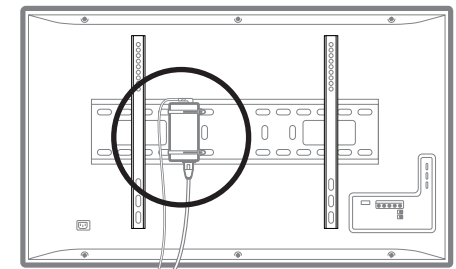

AUDIO INPUT CABLE INSTALLATION

For use when the 3.5mm audio cable option is purchased as an add-on, or added at a later date. In order to prevent the input audio jack, or the 3.5mm plug to become damaged during above ceiling work, an auxiliary input protection bridge is provided to provide strain relief.

1. Locate the protection bridge on the side of the Topcat.
2. Plug the 3.5mm audio cable into the AUDIO IN or Power jack on the side of the Topcat.
3. Secure the audio cable to the protection bridge using a zip tie.

NOTE: Take precautions as necessary to prevent and guard against electromagnetic and electrostatic noise interference. Long cable runs, unshielded and / or poorly shielded cable, multiple ground paths and improper grounding may all contribute to the production of a low frequency hum. In most cases a ground loop isolator (not provided) placed in line will attenuate or possibly eliminate the hum.

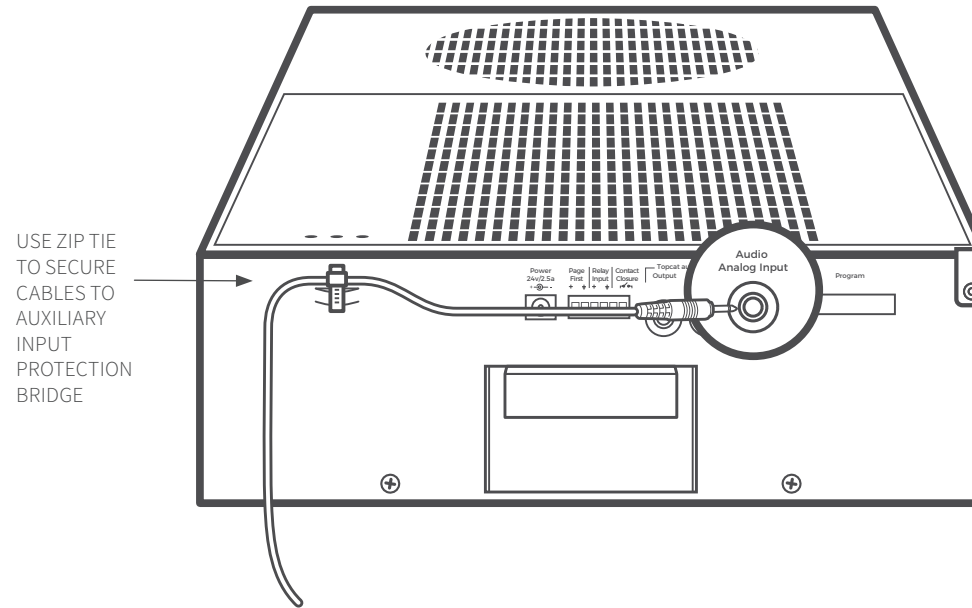

SETUP AND USING THE FLEXMIKE

NOTE: This procedure is easier with two people.

1. Ensure that Topcat is powered on. The white LED on will glow.
2. Remove the Flexmike from the cradle charger. Flexmike will automatically power on and mute when it is removed from the charger.
3. Fasten the Flexmike lanyard around the neck by connecting the magnetic clasps. Adjust the lanyard so that the top of the microphone is at the collarbone.
4. While speaking in a normal voice, fine-tune the microphone volume by adjusting the up or down buttons on the microphone.
 - Your voice should be clearly heard by another person on the other side of the room.
 - You should barely be able to hear your own voice.
 - There should not be any audio “feedback” or squealing outside of 2-3 feet (if there is, turn the volume down slightly).
5. Once initial volume level is set, walk around the room and listen for overall audio quality.
6. The teacher can now use the controls on the Flexmike to adjust the volume level from anywhere in the room.
7. Repeat step 6 for a second Flexmike, if purchased.
8. If a Sharemike was purchased, set the Sharemike volume.

TIPS TO OBTAIN OPTIMUM AUDIO PERFORMANCE

- Speak in a natural voice. A normal conversational speech level will provide an adequate signal. It is not necessary to increase the intensity of your voice—the audio system provides adequate amplification (approximately 5 – 10 dB) above ambient room noises.
- Avoid wearing jewelry that may rub or bump against the microphone.
- Mute the Flexmike during private conversations by momentarily pressing the power button. When muted, the blue light turns white.
- When the conversation is over, unmute the Flexmike by momentarily pressing the power button again. The white light will turn blue.
- Recharge microphone(s) each night. When recharged nightly, the microphone will last through a typical school day.

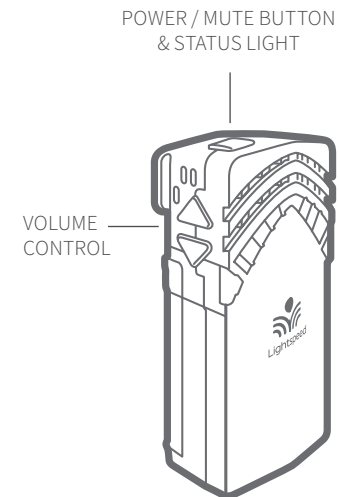
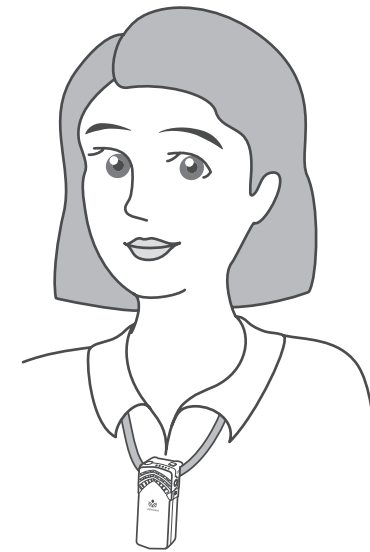

CHARGING THE FLEXMIKE

Before use, the Flexmike should be charged. It will take 5-6 hours for the Flexmike to obtain a full charge. A fully charged Flexmike will last for up to 8 hours of use. If microphones are used daily, they should be charged each night.

When properly inserted into a cradle charger the red light on the Flexmike power button indicates the battery pack is charging. The power status light will glow green to indicate that charging is complete and a full charge has been reached.

Replacement Lithium Ion battery packs may only be purchased through Lightspeed Technologies (part #L3.7V).

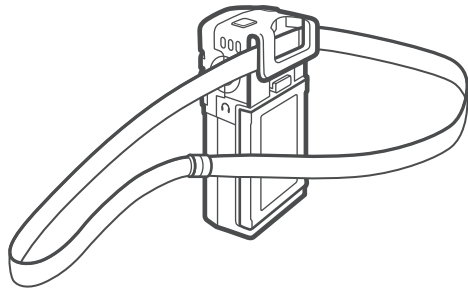

ATTACH LANYARD

Hang the Flexmike on the lanyard opposite the magnetic clasp.

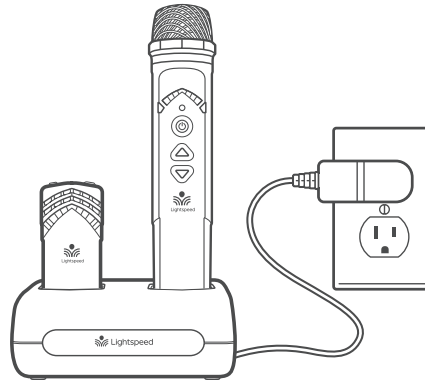

CONNECT CRADLE CHARGER

Plug power cord into the cradle charger and then plug the AC end into an electrical outlet.

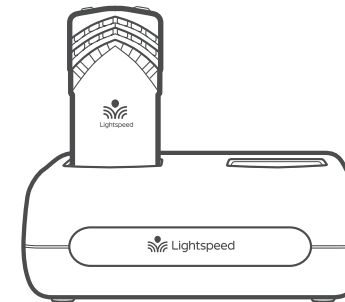

CHARGE MICROPHONE

Place the Flexmike into the cradle. The LED on the Flexmike power status light will glow red indicating charging has started.

If Activate speaker pods were purchased with your Topcat system, the Flexmike will be charged in the Activate Charging Station. Please see the ACT User Manual for instruction.

INSTALLING OPTIONAL EQUIPMENT

PageFirst Installation

The following components are included when the PageFirst option is purchased as an add-on:

- PageFirst Sensor Clip with wire pigtail (PFSC)
- 50' length of shielded plenum wire, wire nuts

CONNECT PAGEFIRST SENSOR CLIP TO PAGING SPEAKER

If possible, the PageFirst Sensor Clip (PFSC) should be hung around one of the 8-ohm lead wires that connects directly to the paging speaker. If it's a sealed ceiling speaker, where only the 25V/70V wire is accessible, then connect the page first sensor clip as follows:

1. Locate the paging speaker in the classroom.
2. Locate the PageFirst Sensor Clip. The clip is designed to hang around a single conductor (either + or -) of the 25V/70V paging speaker wire. **NOTE:** The PageFirst sensor operates via induction and is not compatible with telephone or IP Paging Systems as these digital signals do not produce sufficient induction current.
3. Strip back the outer cable jacket of the 25V/70V speaker cable to gain access to the two speaker cable conductors. Hang the PageFirst Sensor Clip around one of the two conductors. It's a best practice to wrap the single conductor around the clamp to ensure current induction (Figure 1).

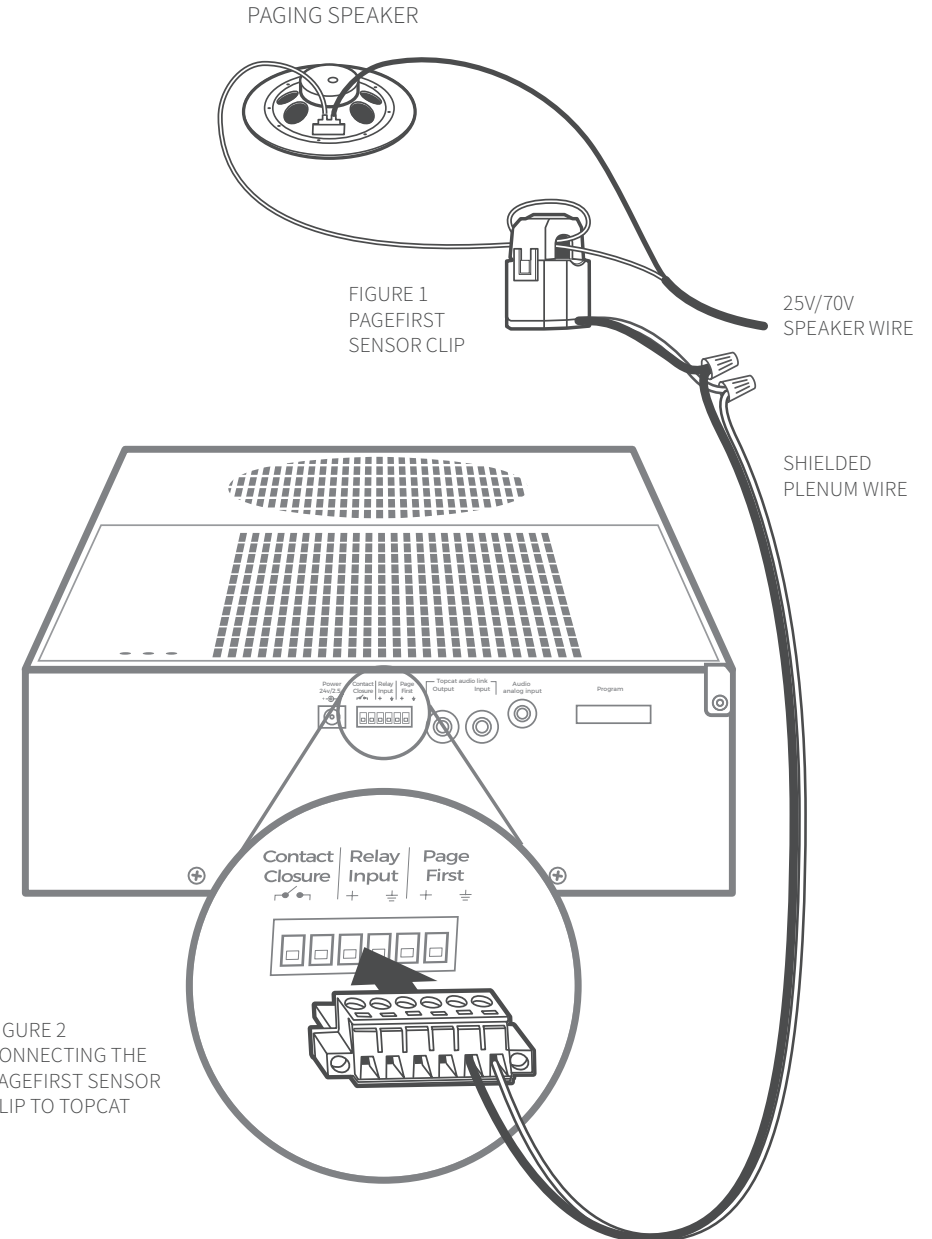



PageFirst Installation CONT'D

CONNECTING THE PAGEFIRST SENSOR TO TOPCAT

The sensor needs to be hard-wired back to Topcat.

1. Insert the euro-block connector of the wire into the PageFirst input jack on Topcat. Secure with a screw driver by tightening the screw on the left and right sides of the terminals (Figure 2, previous page).
2. Route the wire from Topcat to the paging speaker.
NOTE: When routing wire, make sure to secure the wire to the building structure, as electrical and building codes require.
3. Connect the pigtail of the sensor clip to the length of wire, using the provided wire nuts. Coil and secure excess wire as needed. Wire can be cut and stripped to the appropriate length if necessary.

TESTING PAGEFIRST

A page will need to be broadcast through the system to verify PageFirst is properly sensing the audio signal.

1. Turn on the system and begin speaking.
2. Broadcast a page through the central paging system.
3. Topcat should mute as the page is broadcast. When the broadcast is over, Topcat should amplify the mic as normal.
4. While walking around the room, continue talking into the microphone. Verify that the system is not muting during times there is no page being broadcast.

ADJUSTING THE SENSITIVITY

1. If the systems does not mute while a page is being broadcast, increase sensitivity by turning the ADJ knob clockwise and test again.
NOTE: If mute is not still achieved after ADJ is adjusted to maximum, it might be necessary to make additional loops of the paging cable conductor around the PageFirst Sensor Clip. A maximum of five loops is recommended.
2. If the system mutes during times when a page is not being broadcast, decrease sensitivity by turning the ADJ knob counterclockwise and test again.
NOTE: If the system continues to mute prematurely, the paging cable conductor might be wrapped around the Page First Sensor Clip too many times. Reduce the conductor wraps to a single wrap.



NOTE: The PageFirst function works via current induction. The above instructions represent the most common method to achieve sufficient induction. If sufficient induction is not achieved to trigger this function, please contact Lightspeed regarding alternate installation methods.

Take precautions as necessary to prevent and guard against electromagnetic and electrostatic noise interference. Unshielded and/or poorly shielded cable, multiple ground paths and improper grounding may all contribute to the production of a low frequency noise which could result in PageFirst muting incorrectly.

Additional Life Safety Solutions

RELAY INPUT

Topcat contains an input connection to detect a signal from Fire Alarm, IP Paging System or other device. When triggered, audio from Topcat is muted to ensure emergency alerts from external systems can be heard.

The Relay Input can be triggered with either DC voltage between .5V and 24V from a powered relay switch or a resistive short from a fire alarm system.

DC VOLTAGE

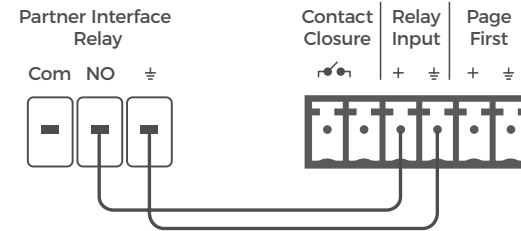

RESISTIVE SHORT

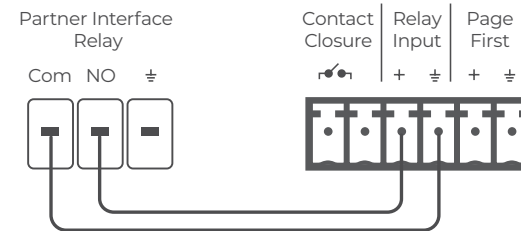

CONTACT CLOSURE

If your building is equipped with an alert notification system, teachers can use the Flexmike microphone to send an alert.

This activates the contact closure function on Topcat, which external systems use to perform a prescribed action, such as notifying the appropriate parties of a classroom alert.

The Contact Closure is a normally open relay that can be closed by pressing the up and down volume buttons at the same time for 3 seconds on the Flexmike.

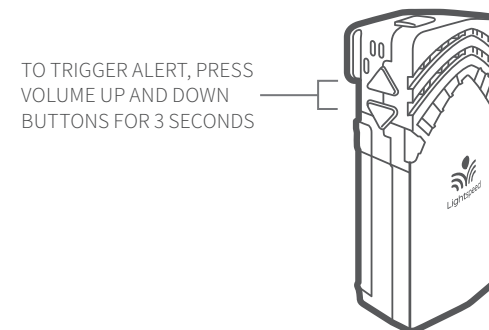

Media Connector Set-Up

DETERMINE SET-UP LOCATION

Choose a location for the Media Connector that is convenient to the classroom audio sources and power supply.

The Media Connector can be placed on a counter or wall mounted. Determine the best location for your room. Use the guidelines below when selecting the site.

Set it up in a convenient place near a power source that is highly accessible for both teachers and students. If plugging in multimedia audio sources, it should be located in close proximity to minimize cable runs.

Key considerations:

- Near multimedia audio sources if desired
- Do not place in a fully enclosed metal cabinet

COUNTER OR DESKTOP

- Locate 3-6 feet off of the floor to allow for best transmission.

WALL MOUNTING

- Find a location on the wall that is near the computer or other AV equipment that will be connected to the Media Connector.
 - Power for the Media Connector must be within 6 ft of this location.
1. Hold Media Connector up to the wall and ensure that it is level. Mark the mounting holes with a pencil. The back of the Media Connector that contains the inputs may be mounted in any position that is desirable.
 2. For sheetrock walls, use screw-in sheetrock anchors and screws (not supplied) to secure the Media Connector to the wall. It is best to drill a 1/4" pilot hole at the two mounting locations before inserting the anchors.
 3. Once the anchors are installed, place the Media Connector over the mounting anchors and insert screws through the mounting holes and into the anchor.
 4. If walls are concrete or cinder block, appropriate mounting hardware should be purchased locally.

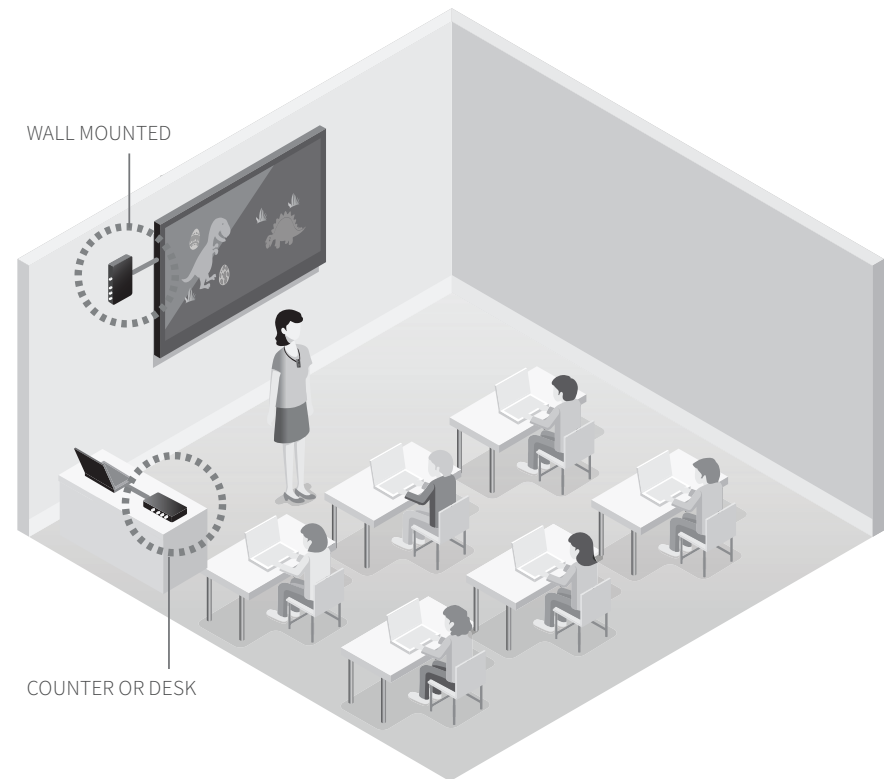

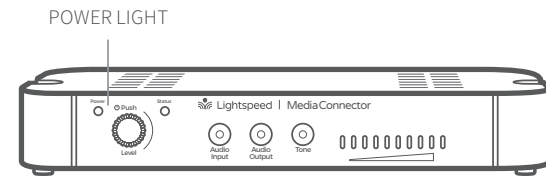
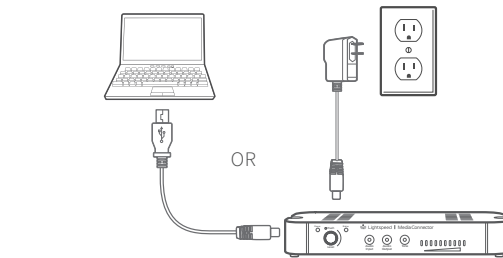
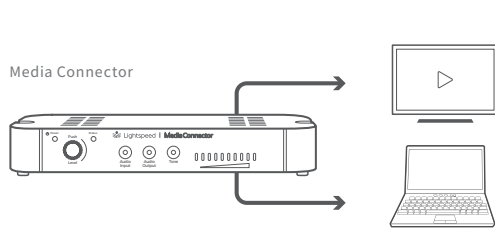

1 DETERMINE LOCATION

Media Connector is designed to be connected to the primary media source in the classroom, usually the computer or display panel.

2 CONNECT TO POWER

Connect the USB cable power cord to a computer, or use the USB power adapter to plug into wall outlet.

Plug the USB cable into the USB input on the back of the Media Connector.

3 POWER ON

When powered on, the white LED on the front panel will glow.

Topcat does not need to be powered off at the end of day, but if desired, you may power down Topcat by powering down the Media Connector.

CONNECTING MEDIA CONNECTOR TO AUDIO

Audio can be connected using either a digital 2-way USB audio or analog audio.

USB Audio

If locating and connecting to computer USB, Media Connector will default to digital USB audio (3.5mm analog audio ports will be disabled). USB audio enables a 2-way audio link to:

Send audio from the computer to the Topcat to ensure all audio can be played through the Topcat speaker.

Send audio to the computer from the Topcat to ensure the teacher's Flexmike and any student microphones are clearly picked up by a video conferencing solution.

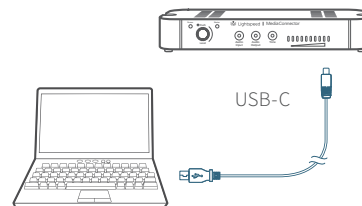

COMPUTER SETTINGS

Once connected, open computer sound setting to select "Lightspeed Audio" as the microphone and speaker.

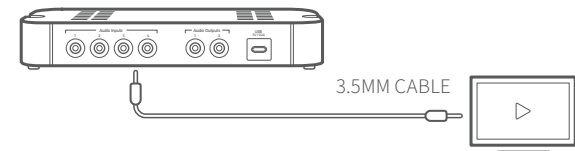

Analog Audio

Plug your external audio equipment (e.g., video display) into one of the Audio input jacks.



Adjust the volume as needed by pressing the Audio Input selector and adjusting the level knob as needed.

VOLUME ADJUSTMENT FOR THE MEDIA CONNECTOR

The Media Connector can be used as the primary volume control for the audio sources to be connected.

1. Connect the audio source(s) to the Media Connector using the 3.5mm cables provided.
2. Press the power button to power on the unit.
3. Set the audio source volume to provide sound through Topcat.
4. Use the Media Connector Audio In volume control to increase or decrease the sound level.

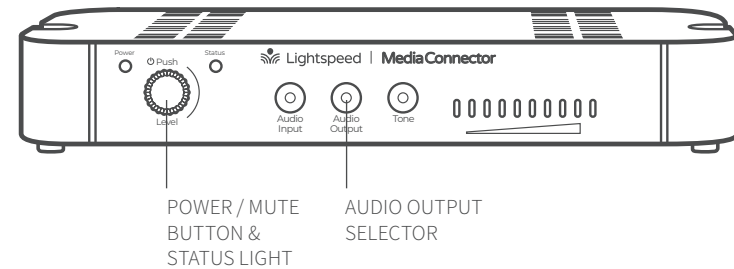

NORMALIZING AUDIO SOURCE VOLUME LEVELS

Use the Media Connector as the master audio volume control for the classroom. When two or more audio sources are connected, you will need to normalize volume settings by setting all connected audio sources to the same sound level while leaving the Media Connector Audio In volume control set to its center setting. The Media Connector is an audio mixer using a master volume control to adjust the volume of all audio sources at once. Use the following procedure to set audio source volumes:

1. Connect the multimedia audio sources to the Media Connector using the 3.5mm cables provided.
2. Set the Audio In volume control on the Media Connector to its center position.
3. Turn on an audio source that does not have an accessible audio level control. (DVD player)
4. Adjust the Media Connector Audio In volume control so the audio level playing through the speaker is appropriate for the classroom.
5. Turn off the first audio source.
6. Turn on the second audio source. Use its volume control to balance the audio output to the same audio level played through the speaker as the first source.
7. Repeat steps 5 and 6 for the remaining audio sources.

8. Now, the Media Connector's Audio In volume can be used to increase or decrease the volume level for all audio sources as desired.

USB AUDIO INPUT INTERFACE

- To disable USB interface:
 1. Remove power from Media Connector.
 2. Press and hold Audio Out button while powering Media Connector back on.
 3. USB interface is set to disable.
 4. Status light will turn white to indicate USB is disabled.
 5. Reboot Media Connector by removing and plugging in power supply.
- To enable USB interface:
 1. Remove power from Media Connector.
 2. Press and hold Audio Out button while powering Media Connector back on.
 3. USB interface is set to enable.
 4. Status light will turn blue to indicate USB enabled.
 5. Reboot Media Connector by removing and plugging in power supply.



NOTE ON REGISTRATION: The Topcat and Media Connector are paired together as a pair at the Lightspeed factory as required for proper operation. If paired Topcat and Media Connector are separated and swapped during the installation process, they must be re-paired. Please refer to the pairing instructions at www.lightspeed-tek.com.

OPTIONAL MEDIA CONNECTOR AUDIO INTEGRATION

The Media Connector is designed to integrate multiple audio sources quickly and easily allowing other instructional technologies to be clearly heard throughout the classroom quickly and easily.

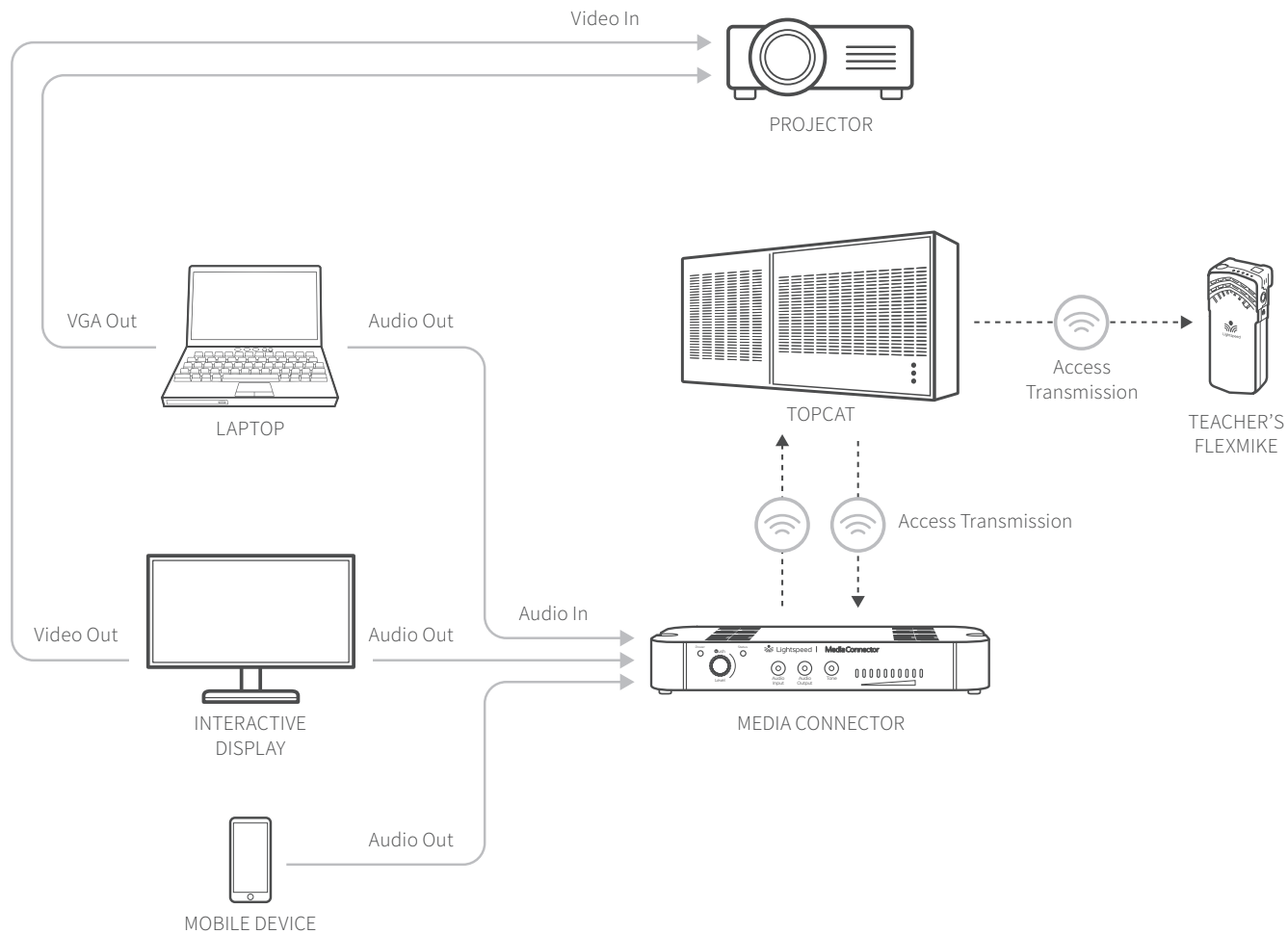

NOTE ON INTEGRATION: If Media Connector is not included in installation, a 3.5mm audio cable may be connected from the audio source to the audio input on side of Topcat. Take precautions as necessary to prevent and guard against electromagnetic and electrostatic noise interference. Long cable runs, unshielded and / or poorly shielded cable, multiple ground paths and improper grounding may all contribute to the production of a low frequency hum. In most cases a ground loop isolator (not provided) placed in line will attenuate or possibly eliminate the hum.



Audio Input Cable Installation

For use when the 3.5mm audio cable option is purchased as an add-on, or added at a later date.

In order to prevent the input audio jack or the 3.5mm plug to become damaged during above ceiling work, a auxiliary input protection bridge is provided to provide strain relief.

1. Locate the protection bridge on the side of the Topcat.
2. Plug the 3.5mm audio cable into the AUDIO IN jack on the side of the Topcat.
3. Secure the audio cable to the protection bridge using a zip tie (not provided).

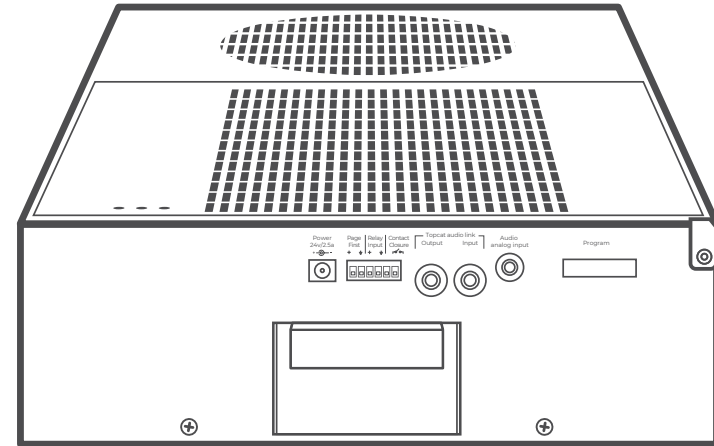

NOTE: Take precautions as necessary to prevent and guard against electromagnetic and electrostatic noise interference. Long cable runs, unshielded and / or poorly shielded cable, multiple ground paths and improper grounding may all contribute to the production of a low frequency hum. In most cases a ground loop isolator (not provided) placed in line will attenuate or possibly eliminate the hum.

Safety Warnings and Certifications



CAUTION
RISK OF ELECTRICAL SHOCK
DO NOT OPEN



THIS PRODUCT MUST BE INSTALLED IN ACCORDANCE WITH THE APPLICABLE INSTALLATION CODE BY A PERSON FAMILIAR WITH THE CONSTRUCTION AND OPERATION OF THE PRODUCT AND THE HAZARDS INVOLVED.



The lightning flash with arrowhead symbol inside an equilateral triangle is intended to alert the user to the presence of non insulated “hazardous voltage” within the product’s enclosure, which may be of sufficient magnitude to induce a risk of electric shock to persons.



The exclamation mark inside an equilateral triangle is intended to alert the user to the presence of important operating and maintenance (servicing) instruction in the literature accompanying this product.



USE A LIGHTSPEED SUPPLIED BATTERY ONLY



USE 12-14 AWG WIRING ONLY



CAUTION: Risk of explosion if battery is replaced by an incorrect type. Dispose of used batteries according to the instructions.



Battery subjected to extremely low air pressure that may result in an explosion or the leakage of flammable liquid or gas.



This product is listed to UL standards and requirements for electrical safety by Underwriters Laboratories Inc.



This product conforms with the essential requirements of the following European Union Directives: 2014/30/EU Electromagnetic Compatibility (EMC), 2014/35/EU Low Voltage Directive (LVD) and 2014/53/EU Radio Equipment (RED).



Lightspeed Technologies launched a formal product recycle program in Europe that complies with the European Union Directive 2012/19/EU on Waste Electrical and Electronic Equipment (“WEEE Directive”). Please visit our website at www.Lightspeed-tek.com for more information.



This product is manufactured using lead-free processes and is free of other materials harmful to the environment. It conforms to the most stringent new European guidelines for consumer products (RoHS).

Précautions De Sécurité et Certifications





ATTENTION

RISQUE D'ÉLECTROCUTION

NE PAS OUVRIR



CONFORMÉMENT AUX NORMES D'INSTALLATION APPLICABLES, CE PRODUIT DOIT ÊTRE INSTALLÉ PAR UNE PERSONNE FAMILIARISÉE AVEC LA CONCEPTION ET LE FONCTIONNEMENT DU PRODUIT ET CONSCIENTE DES RISQUE ENCOURUS.

L'éclair flèche dans un triangle équilatéral avertit l'utilisateur de la présence d'une "tension dangereuse" non isolée à l'intérieur de l'appareil, qui peut être d'une ampleur suffisante pour constituer un risque d'électrocution.

Le point d'exclamation contenu dans un triangle équilatéral avertit l'utilisateur de la présence d'importantes instructions d'exploitation et de maintenance dans la documentation qui accompagne ce produit.



UTILISEZ UNIQUEMENT LA BATTERIE LIGHTSPEED FOURNIE



UTILISER 12-14 AWG UNIQUEMENT



ATTENTION: Risque d'explosion si la batterie est remplacée par un type incorrect. Mettre au rebus les batteries usagées selon les instructions.



Ce produit est certifié conforme aux normes et aux exigences UL en matière de sécurité électrique par Underwriters Laboratories Inc.



Ce produit est conforme aux principales exigences des directives de l'Union Européenne suivantes: 2014/30/ EU Electromagnetic Compatibility (EMC), 2014/35/ EU Low Voltage Directive (LVD) and 2014/53/EU Radio Equipment (RED).



Lightspeed Technologies a lancé un programme de recyclage de produits en Europe conformément à la directive de l'Union Européenne 2012/19/EU relative aux déchets d'équipements électriques et électroniques (directive « DEEE »). Veuillez visiter notre page Web www.lightspeed-tek.com pour plus de renseignements.



Ce produit est fabriqué en utilisant des processus sans plomb ni aucune autre matière nuisible à l'environnement. Il est conforme aux nouvelles règles européennes les plus strictes en matière de biens de consommation (RoHS).

TROUBLESHOOTING

COMMON PROBLEMS AND SOLUTIONS

Most problems are related to low battery power. Use fully-charged batteries in good condition.

BATTERY CHECK

- Confirm batteries are charged each night. A red light on the battery status light indicates a low battery.
- Make sure the microphones obtain a full charge. A full charge takes 5-6 hours.
- When charging transmitter, ensure the red charging light turns on. The green light will turn on when a full charge is reached.

PROBLEM: Low volume or feedback

SOLUTION: Follow these steps to eliminate low volume or feedback.

- Adjust the volume level on the microphone.
- Check microphone volume level on the amplifier. If the volume is too high, feedback will occur. Adjust accordingly.
- Check input volume level on the amplifier. If the volume is too high, feedback will occur. Adjust accordingly.

PROBLEM: No sound from speaker and wireless components

SOLUTION: Follow these steps to produce sound from amplifier.

- Confirm that the white POWER light located on the front panel of the amplifier is on.
- Confirm the microphone is powered on and linked to the amplifier. The mic 1 or 2 status light will be white on the microphone indicating the microphone is linked.
- Confirm that the microphone is turned on. There will be a solid blue light on the top of microphone to indicate it is powered on and ready.
- Confirm that microphone is not muted. A solid white light on the top of microphone will indicate it is muted.

- Check speaker connections on the amplifier. Make sure the cables are properly connected (see page 31 of this manual for more information).
- If an Activate Station or Media Connector is paired with Topcat, make sure that the volume level of the Activate Station or Media Connector is not turned down all the way. Slowly increase the volume level while talking into the microphone.

If you review these instructions and still have questions, call Lightspeed Technical Services at 800.732.8999, 5am – 5pm, PST. Customers outside the U.S. should contact their local reseller.



TIPS TO OBTAIN OPTIMUM AUDIO PERFORMANCE

- **Speak in a natural voice.** A normal conversational speech level will provide an adequate signal. It is not necessary to increase the intensity of your voice—the audio system provides adequate amplification above ambient room noises.
- **Avoid wearing jewelry that may rub** or bump against the microphone.
- **Mute the microphone during private conversations** with a student, parent, or other classroom visitor. You can tell the mic is muted when the light turns white.
- **Recharge microphones each night.** When recharged nightly, operating time (actual usage) for the microphones will last through a typical school day.



83-TCN-A



Dedicated to Access for All

We create instructional audio and video solutions that unlock student access to learning opportunities and give teachers meaningful insights into moment-by-moment learning.

11509 SW HERMAN ROAD
TUALATIN, OREGON 97062
TOLL FREE: 800.732.8999
PHONE: 503.684.5538
FAX: 503.684.3197
LIGHTSPEED-TEK.COM